

400-2.5kW Fan cooled



The flexPower series is a range of modular power supplies which can be configured into a bespoke solution for quick delivery of samples, prototypes and low volume production.

The range consists of 8 power platforms ranging from 400W to 2.5kW and 14 modules ranging from 3.3V at 66W to 60V at 750W. The modules can be placed in series or in parallel to give a single output at the chassis rating.

Signals are floating and allow for configuration as active low or active high and include AC OK, global DC OK, module DC OK and current monitor. There is a global inhibit signal which can alternatively be configured as a global enable.

flexPower consists of a chassis of the required power level in which there are 10 slots in versions rated up to 700W, 12 slots for the 900W version, 14 slots for the 1kW version and 16 slots in the 1.5kW version. An extra 200W of power is available from X4, X5, X7, X9 & X10 chassis at high line and an extra 1kW is available from the X15 chassis at high line. The flexPower chassis can be specified as industrial or medical (XM models) types.



Features

- ▶ 400W to 1.5kW low line 600W to 2.5kW high line fan cooled
- ▶ Configurable for fast time to market
- ▶ 10/12/14/20 slot models
- ▶ Output modules 3V3 to 60VDC
- ▶ Module power up to 750W
- ▶ Input range 85 to 264VAC
- ▶ Flexible series & parallel capability
- ▶ ITE & industrial or medical (2 x MOPP) versions
- ▶ SEMI F47 compliant
- ▶ Fan speed control
- ▶ -20°C to +70°C operating temperature
- ▶ 3 year warranty

Applications

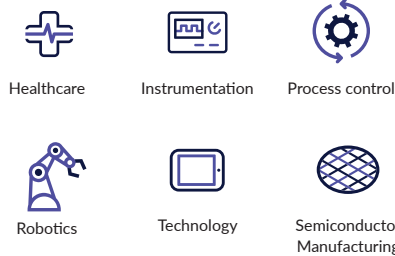

Dimensions

See mechanical details

Documentation

For further information click the link or scan the code

→ xppower.com



Configuration Examples

The fleXPower range allows for simple configuration of a custom modular power supply with up to twenty outputs. The chassis consists of either ten, twelve, fourteen or twenty slots, and modules are either two, three or four slots wide. Please refer to next page for specific X15 configuration information.

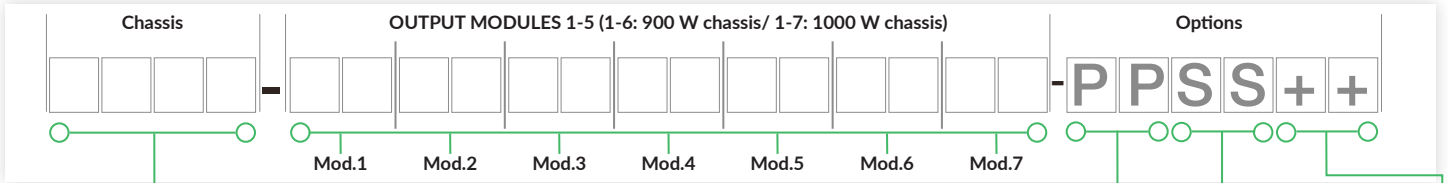

Model	Sector	V input				Slots
		115V		230V		
		Pnom	Ppk*	Pnom	Ppk*	
X4	Industrial	400W	800W	600W	1200W	10
XM4	Medical	400W	800W	600W	1200W	10
X5	Industrial	500W	800W	700W	1200W	10
XM5	Medical	500W	800W	700W	1200W	10
X7	Industrial	700W	800W	900W	1200W	10
XM7	Medical	700W	800W	900W	1200W	10
X9	Industrial	900W	1100W	1100W	1500W	12
XM9	Medical	900W	1100W	1100W	1500W	12
X10	Industrial	1000W	1300W	1200W	1600W	14
XM10	Medical	1000W	1300W	1200W	1600W	14

Note: Peak power available for 10 seconds with 35% duty cycle.

Step 1

To configure your fleXPower unit, select the required output power and application type. fleXPower chassis are available in multiple power formats.

Step 2

FleXPower can accommodate up to ten modules, resulting in an extensive range of output combinations. However, as all modules are designed to fit across either 2, 3 or 4 slots in the chassis, configuration is very simple. Select the appropriate modules for your output requirements, ensuring that all modules will fit in the chassis. First, insert 7 or 4 series modules, ordered lowest voltage to highest. Next in order, insert 3 series modules, ordered lowest voltage to highest. Follow with 2 series, then 5 series dual output, ordered alphabetically a-z. then 1 series, ordered lowest voltage to highest. Modules are sequenced left-to-right in the configuration code, but loaded into the chassis right-to-left, when viewed from the output end of the chassis.

Step 3

Add any required options. These are grouped into three types; parallel options, series options and other options. The standard signal set for each chassis includes Global Inhibit, Global DC OK and Global AC OK, each having logic 0 operation. Optionally a logic 1 operating version of each is available along with reverse air flow. Also available is a fan speed control option, which is available separately or combined with previously listed options.

Dual Output - Module Voltage/Current Rating					
Output 1		Output 2		Slot	Code
Voltage	Current	Voltage	Current		
5.0V	10.0 A	5.0V	10.0 A	2	5A
5.0V	10.0 A	3.3V	10.0 A	2	5B
12.0V	10.0 A	12.0V	8.0 A	2	5D
15.0V	8.0 A	15.0V	6.0 A	2	5E
15.0V	8.0 A	12.0V	8.0 A	2	5F
12.0V	10.0 A	5.0V	10.0 A	2	5G
12.0V	10.0 A	3.3V	10.0 A	2	5H
12.0V	10.0 A	2.0V	10.0 A	2	5K
15.0V	10.0 A	5.0V	10.0 A	2	5J
15.0V	10.0 A	3.3V	10.0 A	2	5L
15.0V	10.0 A	2.0V	10.0 A	2	5M
24.0V	6.0 A	5.0V	10.0 A	2	5N
24.0V	6.0 A	3.3V	10.0 A	2	5P
24.0V	6.0 A	2.0V	10.0 A	2	5Q

Note: 5x modules require 10% load on output 1 to meet specified regulation on output 2.

Total power for dual output module must not exceed 175 W.

Single Output - Module Voltage/Current Rating						
Voltage	Current	l _{pk}	Power	P _{pk}	Slots	Code
3.3V	20.0A	n/a	66W	n/a	2	1C
3.3V	40.0A	n/a	132W	n/a	2	2C
3.3V	60.0A	n/a	198W	n/a	3	3C
5.0V	20.0A	n/a	100W	n/a	2	1D
5.0V	40.0A	n/a	200W	n/a	2	2D
5.0V	60.0A	n/a	300W	n/a	3	3D
8.0V	25.0A	n/a	200W	n/a	2	2H
10.0V	20.0A	n/a	200W	n/a	2	2I
10.0V	30.0A	n/a	300W	n/a	3	3I
12.0V	8.50A	n/a	102W	n/a	2	1J
12.0V	17.0A	n/a	204W	n/a	2	2J
12.0V	25.0A	n/a	300W	n/a	3	3J
12.0V	62.5A	n/a	750W	n/a	4	4J ⁽²⁾
12.0V	62.5A	n/a	750W	n/a	4	7J
15.0V	7.00A	n/a	105W	n/a	2	1L
15.0V	14.0A	n/a	210W	n/a	2	2L
15.0V	20.0A	n/a	300W	n/a	3	3L
15.0V	50.0A	n/a	750W	n/a	4	4L ⁽²⁾
15.0V	50.0A	n/a	750W	n/a	4	7L
18.0V	16.7A	n/a	300W	n/a	3	3N
24.0V	5.00A	n/a	120W	n/a	2	1P
24.0V	10.5A	n/a	252W	n/a	2	2P
24.0V	17.0A	n/a	408W	n/a	3	3P
24.0V	31.5A	n/a	750W	n/a	4	4P ⁽²⁾
24.0V	31.5A	n/a	750W	n/a	4	7P
24.0V	5.00A	10.0A	120W	240W	2	1R ⁽¹⁾
24.0V	10.5A	21.0A	252W	504W	2	2R ⁽¹⁾
24.0V	17.0A	34.0A	408W	816W	3	3R ⁽¹⁾
28.0V	4.50A	n/a	126W	n/a	2	1Q
28.0V	9.00A	n/a	252W	n/a	2	2Q
28.0V	14.0A	n/a	392W	n/a	3	3Q
28.0V	26.8A	n/a	750W	n/a	4	4Q ⁽²⁾
28.0V	26.8A	n/a	750W	n/a	4	7Q
30.0V	8.4A	n/a	252W	n/a	2	2S
30.0V	13.5A	n/a	405W	n/a	3	3S
36.0V	3.50A	n/a	126W	n/a	2	1U
36.0V	7.00A	n/a	252W	n/a	2	2U
36.0V	11.0A	n/a	396W	n/a	3	3U
36.0V	21.0A	n/a	750W	n/a	4	4U ⁽²⁾
36.0V	21.0A	n/a	750W	n/a	4	7U
42.0V	9.05A	n/a	400W	n/a	3	3V
48.0V	2.50A	n/a	120W	n/a	2	1W
48.0V	5.20A	n/a	249W	n/a	2	2W
48.0V	8.50A	n/a	408W	n/a	3	3W
48.0V	15.7A	n/a	750W	n/a	4	4W ⁽²⁾
48.0V	15.7A	n/a	750W	n/a	4	7W
60.0V	2.00A	n/a	120W	n/a	2	1Y
60.0V	4.20A	n/a	252W	n/a	2	2Y
60.0V	7.00A	n/a	420W	n/a	3	3Y
60.0V	12.5A	n/a	750W	n/a	4	4Y ⁽²⁾
60.0V	12.5A	n/a	750W	n/a	4	7Y

1. Peak power available for 10 seconds with 35% duty cycle, if peak power rating is exceeded output may latch, recycle input to reset.
2. '4' series modules not recommended for new designs.

Example

X7-3C3L2C-000016 (Leave blank if no options are required)

X7 - 700 W industrial chassis, 10 module slots available.
3C - 3.3V @ 60.0 A. Three slot width module.
3L - 15.0V @ 20.0 A. Three slot width module.
2C - 3.3V @ 40.0 A. Two slot width module.
00 - No parallel option.
00 - No series option.
16 - Fan speed control card.

Parallel Option Codes	
Code	Description
00	No parallel required
12	Modules 1 & 2
13	Modules 1 to 3
14	Modules 1 to 4
23	Modules 2 & 3
24	Modules 2 to 4
25	Modules 2 to 5
34	Modules 3 & 4
35	Modules 3 to 5
40	Modules 1 & 2, 3 & 4

Series Option Codes	
Code	Description
00	No series required
12	Modules 1 & 2
13	Modules 1 to 3
23	Modules 2 & 3
24	Modules 2 to 4
40	Modules 1 & 2, 3 & 4

Other Option Codes	
Code	Description
01	Reverse Air
02	Global Enable - Logic 1
03	Option 01 & 02
04	Global DC OK - Logic 1
05	Option 01 & 04
06	Option 02 & 04
07	Option 01, 02 & 04
08	Global AC OK - Logic 1
09	Option 01 & 08
10	Option 02 & 08
11	Option 01, 02 & 08
12	Option 04 & 08
13	Option 01, 04 & 08
14	Option 02, 04 & 08
15	Option 01, 02, 04 & 08
16	Fan Speed Control
17	Option 01 & 16
18	Option 02 & 16
19	Option 04 & 16
20	Option 08 & 16
21	Option 01, 02 & 16
22	Option 01, 04 & 16
23	Option 01, 08 & 16
24	Option 02, 04 & 16
25	Option 02, 08 & 16
26	Option 04, 08 & 16
27	Option 01, 02, 04 & 16
28	Option 01, 02, 08 & 16
29	Option 02, 04, 08 & 16
30	Option 01, 02, 04, 08 & 16

Note: 1. Fancard options 16-30 will occupy 2 slots. See mechanical drawing.

Paralleling is supported only between identical output modules. Modules connected in parallel must have the same output voltage and the same power rating (same module code). Do not parallel different module codes, even if the nominal voltage is the same. If an exception is required, contact XP Power for review.

Example Allowed: 2P + 2P, 3J + 3J+3J, 7P + 7P
Not allowed: 2P + 7P, 3J + 4J, 1P+2P+3P

X15 configuration examples

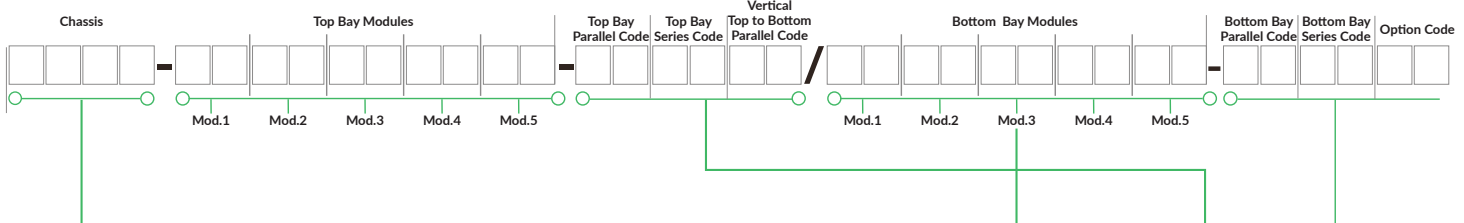

Model	Sector	V input		Slots
		115V	230V	
X15	Industrial	1500W max	2500W max	20
XM15	Medical	1500W max	2500W max	20

Step 1

To configure your fleXPower unit, select the required output power and application type. fleXPower chassis are available in multiple power formats.

Step 2

FleXPower can accommodate up to ten modules, resulting in an extensive range of output combinations. However, as all modules are designed to fit across either 2, 3 or 4 slots in the chassis, configuration is very simple. Select the appropriate modules for your output requirements, ensuring that all modules will fit in the chassis. First, insert 7 or 4 series modules, ordered lowest voltage to highest. Next in order, insert 3 series modules, ordered lowest voltage to highest. Follow with 2 series, then 5 or 6 series dual output, ordered alphabetically a-z. Then 1 series, ordered lowest voltage to highest. Modules are sequenced left-to-right in the configuration code, but loaded into the chassis right-to-left, when viewed from the output end of the chassis.

Step 3

Add any required options. These are grouped into three types; parallel options, series options and other options. The standard signal set for each chassis includes Global Inhibit, Global DC OK and Global AC OK, each having logic 0 operation. Optionally a logic 1 operating version of each is available along with reverse air flow. Also available is a fan speed control option, which is available separately or combined with previously listed options.

Dual Output - Module Voltage/Current Rating					
Output 1		Output 2		Slot	Code
Voltage	Current	Voltage	Current		
5.0V	10.0A	5.0V	10.0A	2	5A
5.0V	10.0A	3.3V	10.0A	2	5B
12.0V	10.0A	12.0V	8.0A	2	5D
15.0V	8.0A	15.0V	6.0A	2	5E
15.0V	8.0A	12.0V	8.0A	2	5F
12.0V	10.0A	5.0V	10.0A	2	5G
12.0V	10.0A	3.3V	10.0A	2	5H
12.0V	10.0A	2.0V	10.0A	2	5J
15.0V	10.0A	5.0V	10.0A	2	5K
15.0V	10.0A	3.3V	10.0A	2	5L
15.0V	10.0A	2.0V	10.0A	2	5M
24.0V	6.0A	5.0V	10.0A	2	5N
24.0V	6.0A	3.3V	10.0A	2	5P
24.0V	6.0A	2.0V	10.0A	2	5Q

Note: 5x modules require 10% load on output 1 to meet specified regulation on output 2.
Total power for dual output modules must not exceed 175W.

Single Output - Module Voltage/Current Rating						
Voltage	Current	Ipk	Power	Ppk	Slots	Code
3.3V	20.0A	n/a	66W	n/a	2	1C
3.3V	40.0A	n/a	132W	n/a	2	2C
3.3V	60.0A	n/a	198W	n/a	3	3C
5.0V	20.0A	n/a	100W	n/a	2	1D
5.0V	40.0A	n/a	200W	n/a	2	2D
5.0V	60.0A	n/a	300W	n/a	3	3D
8.0V	25.0A	n/a	200W	n/a	2	2H
10.0V	20.0A	n/a	200W	n/a	2	2I
10.0V	30.0A	n/a	300W	n/a	3	3I
12.0V	8.50A	n/a	102W	n/a	2	1J
12.0V	17.0A	n/a	204W	n/a	2	2J
12.0V	25.0A	n/a	300W	n/a	3	3J
12.0V	62.5A	n/a	750W	n/a	4	4J ⁽²⁾
12.0V	62.5A	n/a	750W	n/a	4	7J
15.0V	7.00A	n/a	105W	n/a	2	1L
15.0V	14.0A	n/a	210W	n/a	2	2L
15.0V	20.0A	n/a	300W	n/a	3	3L
15.0V	50.0A	n/a	750W	n/a	4	4L ⁽²⁾
15.0V	50.0A	n/a	750W	n/a	4	7L
18.0V	16.7A	n/a	300W	n/a	3	3N
24.0V	5.00A	n/a	120W	n/a	2	1P
24.0V	10.5A	n/a	252W	n/a	2	2P
24.0V	17.0A	n/a	408W	n/a	3	3P
24.0V	31.5A	n/a	750W	n/a	4	4P ⁽²⁾
24.0V	31.5A	n/a	750W	n/a	4	7P
24.0V	5.00A	10.0A	120W	240W	2	1R ⁽¹⁾
24.0V	10.5A	21.0A	252W	504W	2	2R ⁽¹⁾
24.0V	17.0A	34.0A	408W	816W	3	3R ⁽¹⁾
28.0V	4.50A	n/a	126W	n/a	2	1Q
28.0V	9.00A	n/a	252W	n/a	2	2Q
28.0V	14.0A	n/a	392W	n/a	3	3Q
28.0V	26.8A	n/a	750W	n/a	4	4Q ⁽²⁾
28.0V	26.8A	n/a	750W	n/a	4	7Q
30.0V	8.4A	n/a	252W	n/a	2	2S
30.0V	13.5A	n/a	405W	n/a	3	3S
36.0V	3.50A	n/a	126W	n/a	2	1U
36.0V	7.00A	n/a	252W	n/a	2	2U
36.0V	11.0A	n/a	396W	n/a	3	3U
36.0V	21.0A	n/a	750W	n/a	4	4U ⁽²⁾
36.0V	21.0A	n/a	750W	n/a	4	7U
42.0V	9.05A	n/a	400W	n/a	3	3V
48.0V	2.50A	n/a	120W	n/a	2	1W
48.0V	5.20A	n/a	249W	n/a	2	2W
48.0V	8.50A	n/a	408W	n/a	3	3W
48.0V	15.7A	n/a	750W	n/a	4	4W ⁽²⁾
48.0V	15.7A	n/a	750W	n/a	4	7W
60.0V	2.00A	n/a	120W	n/a	2	1Y
60.0V	4.20A	n/a	252W	n/a	2	2Y
60.0V	7.00A	n/a	420W	n/a	3	3Y
60.0V	12.5A	n/a	750W	n/a	4	4Y ⁽²⁾
60.0V	12.5A	n/a	750W	n/a	4	7Y

1. Peak power available for 10 seconds with 35% duty cycle, if peak power rating is exceeded output may latch, recycle input to reset.
2. '4' series modules not recommended for new designs.

Example

X15-3Y3Y-120061/3Y3Y-12 (Leave blank if no options are required)

X15 - 3Y3Y-120061/3Y3Y-12 (leave blank if no options are required)
X15 - 2500W (230VAC) industrial chassis, 20 module slots available.
3Y - 60V @7.00A Three slot width module top bay
3Y - 60V @7.00A Three slot width module bottom bay
3Y - 60V @7.00A Three slot width module top bay

3Y - 60V @7.00A Three slot width module bottom bay
12 - 3Y & 3Y top bay in parallel to give 60V @14.00A
12 - 3Y & 3Y bottom bay in parallel to give 60V @14.00A
61 - 3Y & 3Y top bay in parallel with 3Y & 3Y bottom bay to give 60V @ 28.00A (1680W max).

Parallel Option Codes	
Code	Description
00	No parallel required
12	Modules 1 & 2
13	Modules 1 to 3
14	Modules 1 to 4
23	Modules 2 & 3
24	Modules 2 to 4
25	Modules 2 to 5
34	Modules 3 & 4
35	Modules 3 to 5
40	Modules 1 & 2, 3 & 4

Series Option Codes	
Code	Description
00	No series required
12	Modules 1 & 2
13	Modules 1 to 3
23	Modules 2 & 3
24	Modules 2 to 4
40	Modules 1 & 2, 3 & 4

Vertical Parallel Option Code	
Code	Description
61	Parallel module 1 top bay to module 1 bottom bay

Other Option Codes	
Code	Description
01	Reverse Air
02	Global Enable - Logic 1
03	Option 01 & 02
04	Global DC OK - Logic 1
05	Option 01 & 04
06	Option 02 & 04
07	Option 01, 02 & 04
08	Global AC OK - Logic 1
09	Option 01 & 08
10	Option 02 & 08
11	Option 01, 02 & 08
12	Option 04 & 08
13	Option 01, 04 & 08
14	Option 02, 04 & 08
15	Option 01, 02, 04 & 08
16	Fan Speed Control
17	Option 01 & 16
18	Option 02 & 16
19	Option 04 & 16
20	Option 08 & 16
21	Option 01, 02 & 16
22	Option 01, 04 & 16
23	Option 01, 08 & 16
24	Option 02, 04 & 16
25	Option 02, 08 & 16
26	Option 04, 08 & 16
27	Option 01, 02, 04 & 16
28	Option 01, 02, 08 & 16
29	Option 02, 04, 08 & 16
30	Option 01, 02, 04, 08 & 16

Note: 1. Fancard options 16-30 will occupy 2 slots. See mechanical drawing.

General

Characteristic	Minimum	Typical	Maximum	Units	Notes & Conditions
Efficiency		89		%	
Isolation: Input to Output	4000			VAC	2 x MOPP
Input to Ground	1500			VAC	1 x MOPP
Output to Ground	250			VDC	
Switching Frequency		60		kHz	PFC converter
		200			For modules
Mean Time Between Failures		225		khrs	MIL-STD-217F at 25°C GB
Weight	See mechanical details				

Input

Characteristic	Minimum	Typical	Maximum	Units	Notes & Conditions
Input Voltage - Operating	85		264	VAC	(120-370VDC), full power at 90VAC, derate by 10% at 85VAC. 3 phase input is available, see 3 phase flexPower datasheet.
Input Frequency	47		63	Hz	400Hz (all specifications met at 400 Hz, except leakage current)
Power Factor		0.99			Measured at 115VAC, Full load: 230VAC
Input Current		5.33		VAC	X4 measured at 115VAC, 2.67A at 230VAC
		6.67			X5 measured at 115VAC, 3.33A at 230VAC
		9.33			X7 measured at 115VAC, 4.67A at 230VAC
		12.0			X9 measured at 115VAC, 6.00A at 230VAC
		13.3			X10 measured at 115VAC, 6.67A at 230VAC
		20.0			X15 measured at 115VAC, 10A at 230VAC
Inrush Current			<20	A	X4, cold start at 25°C
					X5, cold start at 25°C
					X7, cold start at 25°C
			<40		X9, cold start at 25°C
					X10, cold start at 25°C
			<60		X15, cold start at 25°C
Earth Leakage Current		<1.5		mA	X models, measured at 264VAC, 50Hz
		<200		µA	XM4-10 models, measured at 264VAC, 50Hz
		<300		µA	XM15 models, measured at 115VAC 60Hz, <400µA at 264VAC 50Hz
Input Protection		T12 / 250		A/V	X4-7/XM4-7, internal fuse in line and neutral
		T15 / 250			X9/XM9, internal fuse in line and neutral
		T20 / 250			X10/XM10, internal fuse in line and neutral
		T30 / 250			X15/XM15, internal fuse in line and neutral

Output

Characteristic	Minimum	Typical	Maximum	Units	Notes & Conditions
Output Voltage					See Modules table
Output Voltage Trim		±6		%	3.3V
		±10			Other
Single Output Modules Voltage Programming	±6			%	0 to 5V applied to Vprog pin (3) provides -6% to +6% trim
Minimum Load	A minimum load of 10% is required on output 1 of the 5 series modules, to achieve regulation. No other minimum load is required.				
Start Up Delay		2		s	
Hold Up Time		20		ms	Measured at 90VAC input & full output load
Line Regulation			<0.1	%	
Load Regulation			<1.0	%	
Ripple & Noise			50/1	mV/% pk-pk	At 20MHz bandwidth, whichever is greater.
Overvoltage Protection	115		130	%Vnom	
Overtemperature Protection		115		°C	Measured internally, auto resetting
Overload Protection	110		140	% I nom	2x, 3x and 4x modules
	110		150		1x modules
	110		150		V1, 5x modules
	110		200		V2, 5x modules
	110		200		
Short Circuit Protection	Continuous trip and restart (hiccup mode)				
Temperature Coefficient			0.03	%/°C	
Remote Sense			0.5	V	Compensates for maximum voltage drop for 0.5V
Enable & Inhibit					See signals page
Current Share					See signals page
Housekeeping Voltage		5V/2A			From each chassis

Environmental

Characteristic	Minimum	Typical	Maximum	Units	Notes & Conditions
Operating Temperature	-20		+70	°C	For operation above +50°C, derate linearly to 50% load at +70°C. Reverse air option derate from +40°C to 50% load at +60°C
Storage Temperature	-40		+85	°C	
Humidity	5		95	%RH	Non-condensing
Operating Altitude		3000		m	Medical
		4000			ITE
Storage Altitude	0		5000	m	
Cooling	Forced air cooling (via field-replaceable internal fan). Fan speed control optional				
Shock	MIL STD-810 Method 516.4 Procedure 1, 30g, half sine, 6 axes				
Vibration	MIL STD-810 Method 514.4 Procedure 1, 1g rms, 5-500Hz, 3 axes				



Emissions - EMC

Phenomenon	Standard	Test Level	Notes & Conditions
Conducted	EN55032	Class B	X version (CISPR22)
	EN60601-1-2	Class A	XM version (CISPR11)
Radiated	EN55032	Class B	X version (CISPR22)
	EN60601-1-2	Class A	XM version (CISPR11)
Harmonic Current	EN61000-3-2	Class A	
Harmonic Fluctuations	EN61000-3-3		

Emissions - immunity

Phenomenon	Standard	Test Level	Criteria	Notes & Conditions
Low Voltage PSU EMC	EN61204-3		As below	
ESD	EN61000-4-2	3	B	±6kV contact, ±8kV air discharge. X10/XM10 models meet level 4, ±8kV contact discharge, ±15kV air discharge
Radiated	EN61000-4-3	10V/m	A	
EFT	EN61000-4-4	3	A	
Surge	EN61000-4-5	Installation class 3	A	
Conducted	EN61000-4-6	3	A	
Magnetic Fields	EN61000-4-8	Various	A	X7, X9, X10: Level 1. XM7, XM9, XM10: Level 2. X15, XM15: Level 5
Dips and Interruptions	EN61000-4-11 (230V)	Int > 95% 5 seconds	B	
		Int 60% 100ms	A	
		Int 30% 10ms	A	
	EN60601-1-2 (230V)	Int > 95% 5 seconds	B	
		Int 60% 100ms	A	
		Int 30% 500ms	A	
SEMI F47-0706	>200VAC input	A		

Safety approvals

Certification	Standard	Notes & Conditions
CB	IEC/EN60601-1	Medical XM models
	IEC/EN62368-1	Industrial X models
UL	ANSI/AAMI ES60601-1, CSA22.2 No.60601-1 per cUL including risk management	Medical XM models
	UL62368-1, CAN/CSA C22.2 No. 62368-1-14	Industrial X models
EN	EN62368-1:2014/A11:2017	
CE	Meets all applicable directives	
UKCA	Meets all applicable legislation	
Equipment Protection Class	Class I	

Signals

Global AC OK/Power Fail

Global AC OK is an isolated transistor of an optocoupler providing a minimum of 5ms warning of loss of output regulation. The signal is fully isolated and the collector and emitter must be connected externally. Maximum sink current 2mA, maximum voltage 20V.

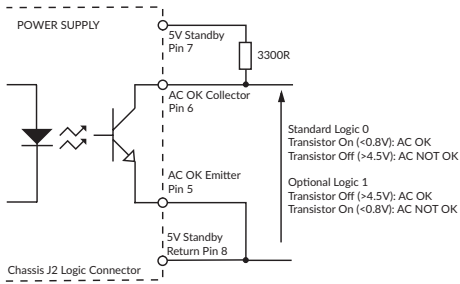

Global DC OK

Global DC OK is an isolated transistor of an optocoupler providing warning that the output voltage has fallen below 90% of nominal. The signal is fully isolated and the collector and emitter must be connected externally. Maximum sink current 2mA, maximum voltage 20V. On Dual output module, DC OK monitors V1 output only.

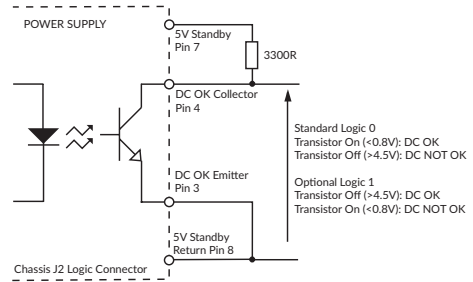

Global Inhibit

Global Inhibit is an isolated control signal input which turns the power supply off by supplying 2 to 5mA into the pin. Global Enable option available, see 'Other Option Codes' table.

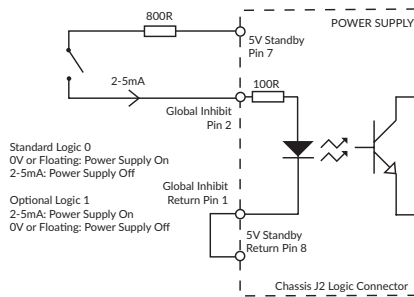

Fan Fail

When fan speed control option is fitted (option 16). Open connector signal warns of any fan failure. Note: Can use 5V standby for 5V EXT.

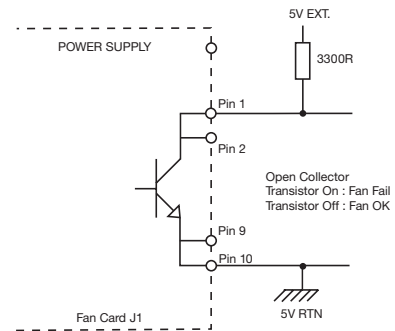

Module DC OK

Module DC OK is a nominal "ON" isolated transistor of an optocoupler which provides a warning of the loss of output regulation on the main output of the module.

Maximum sink current 2mA, maximum voltage 20V.

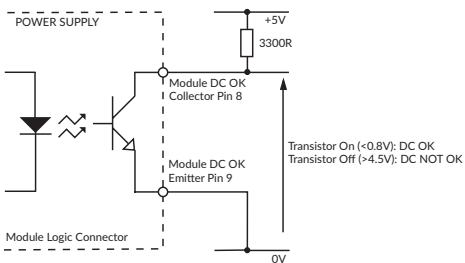

Module Inhibit

Module Inhibit signal is an isolated control signal which turns the module off by supplying 2 to 5mA into the pin. '4' series modules have a 100R internal series resistor. Add resistance as necessary to maintain drive current at 2-5mA.

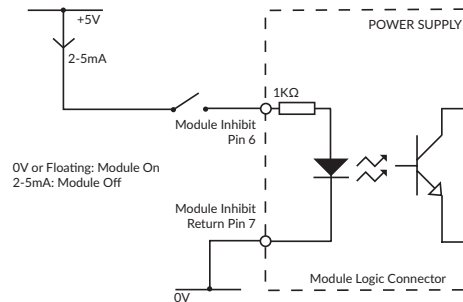

Current Share

Connecting pin 4 of like voltage and power modules (4 maximum) within the same chassis or separate chassis will force the current to share between the outputs.

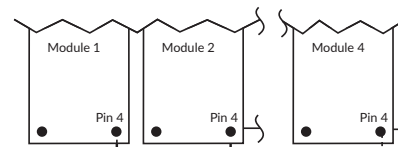

Module Mechanical Details

Single Output

2 Slot Modules

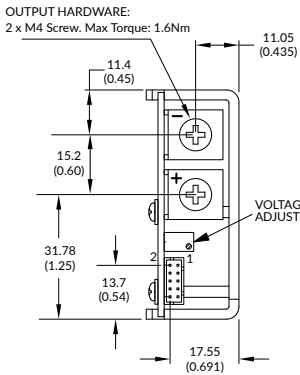

2 Slot Modules (1R/2R Peak)

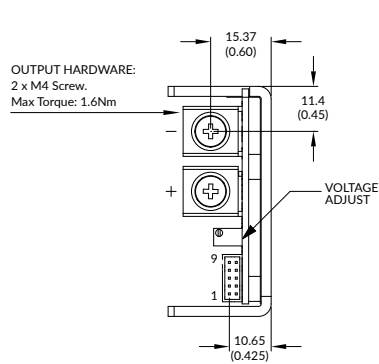

3 Slot Modules (3R Peak)

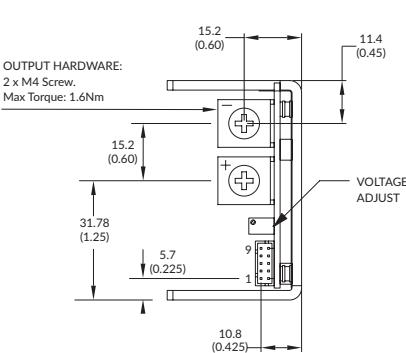

4 slots (4 Series) Modules

OUTPUT HARDWARE: 2 x M4 Screw. Max Torque: 1.6Nm

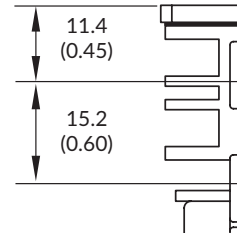

4 slots (7 Series) Modules

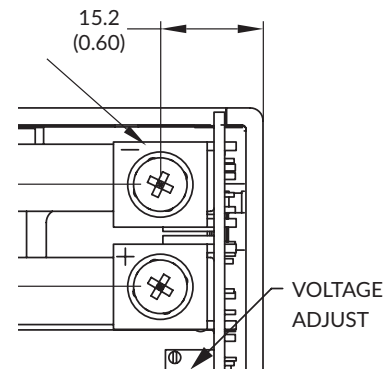

Single Output: Module Logic Connector Pinouts

Pin	Function	Pin	Function
1	Sense +	6	Inhibit Anode
2	Sense -	7	Inhibit Cathode
3	V Prog	8	DC OK Collector
4	I Share	9	DC OK Emitter
5	Not Used	10	Not Used

Notes:

- All dimensions in mm (inches). Tolerance: x.xx (x.x) = ± 0.5 (± 0.02). x.xxx (x.xx) = ± 0.25 (± 0.01)
- Weight: 2/2R Slot: 218g (0.48lb) approx, 3 Slot: 335g (0.74lb), 4 Slot: 431g (0.95lb)
- Mating plug: JST part no. PHDR-10VS.
- Contact: 26-22 AWG JST part no. SPHD 001T-P0.5.
- Connector kit available order part no. flexPower CONKIT.

Dual output

2 Slot

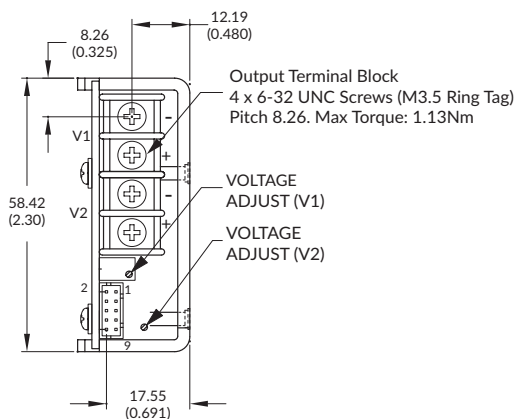

Dual Output: Logic Connector Pinouts

Pin	Function	Pin	Function
1	V1 Sense +	6	Inhibit Anode
2	V1 Sense -	7	Inhibit Cathode
3	Not used	8	DC OK Collector
4	Not used	9	DC OK Emitter
5	V2 Sense +	10	V2 Sense -

Fan speed control card (2 slots consumed)

2 Slot

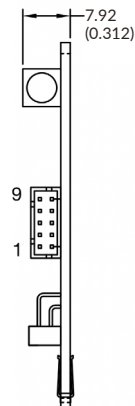

Controls speed of fan(s) depending on output load and thermal environment of the power supply. Also provides warning of any fan failure.

Fan Speed: Logic Connector Pinouts

Pin	Function	Pin	Function
1	Fan Fail	6	Not Used
2	Fan Fail	7	Not Used
3	Not Used	8	Not Used
4	Not Used	9	Ground
5	Not Used	10	Ground

Notes:

- All dimensions in mm (inches). Tolerance: x.xx (x.x) = ± 0.5 (± 0.02). x.xxx (x.xx) = ± 0.25 (± 0.01)
- Weight: Dual: 218g (0.48lb) approx, Slot Module: 45g (0.10lb) approx.
- Mating plug: JST part no. PHDR-10VS.
- Contact: 26-22 AWG JST part no. SPHD-001T-P0.5.
- Connector kit available order part no. flexPower CONKIT.

Mechanical Details

400 (600)⁽⁴⁾ Watt X4 & XM4 Chassis, 500 (700)⁽⁴⁾ Watt X5 & XM5 Chassis, 700 (900)⁽⁴⁾ Watt X7 & XM7 Chassis

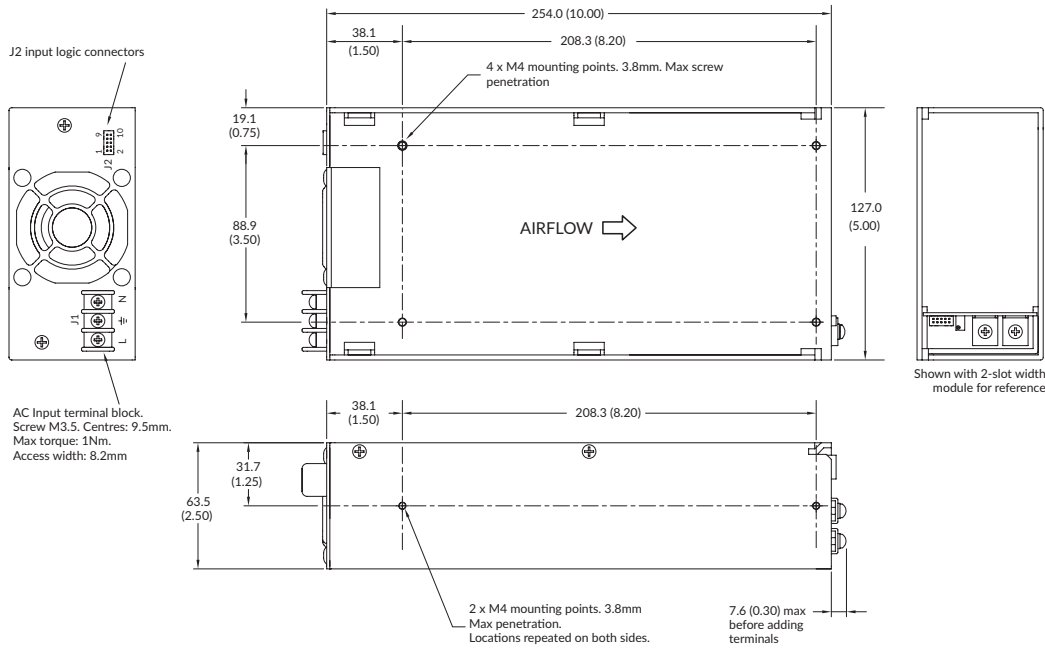

J2 Input Logic Connector Pinouts	
Pin	Function
1	Global Inhibit Cathode
2	Global Inhibit Anode
3	Global DC OK Emitter
4	Global DC OK Collector
5	Global AC OK Emitter
6	Global AC OK Collector
7	5V Standby
8	5V Standby Return
9	Manufacturer Use Only
10	Manufacturer Use Only

900 (1100)⁽⁴⁾ Watt X9 & XM9 Chassis

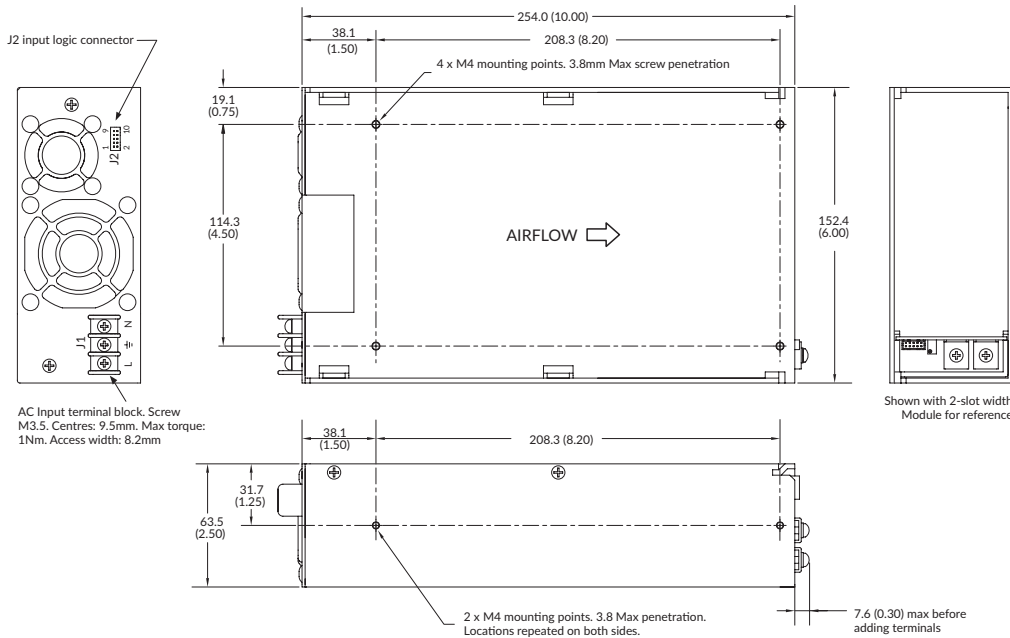

J2 Input Logic Connector Pinouts	
Pin	Function
1	Global Inhibit Cathode
2	Global Inhibit Anode
3	Global DC OK Emitter
4	Global DC OK Collector
5	Global AC OK Emitter
6	Global AC OK Collector
7	5V Standby
8	5V Standby Return
9	Manufacturer Use Only
10	Manufacturer Use Only

Notes:

- All dimensions in mm (inches).
Tolerance x.xx (x.x) = ±0.5 (±0.02). x.xxx (x.xx) = ±0.25 (±0.01)
- Mating plug: JST p/n PHDR-10VS.
- Contact: 26-22 AWG JST p/n SPHD-001T-P0.5.
- High line only (180-264VAC).
- Weights: 400 (600) W X4 & XM4 chassis: 1250g (2.75lbs) approx.
500 (700) W X5 & XM5 chassis: 1250g (2.75lbs) approx.
700 (900) W X7 & XM7 chassis: 1250g (2.75lbs) approx.
900 (1100) W X9 & XM9 chassis: 1500g (3.3lbs) approx.

Mechanical Details

1000 (1200)⁽⁴⁾ Watt X10 & XM10 Chassis

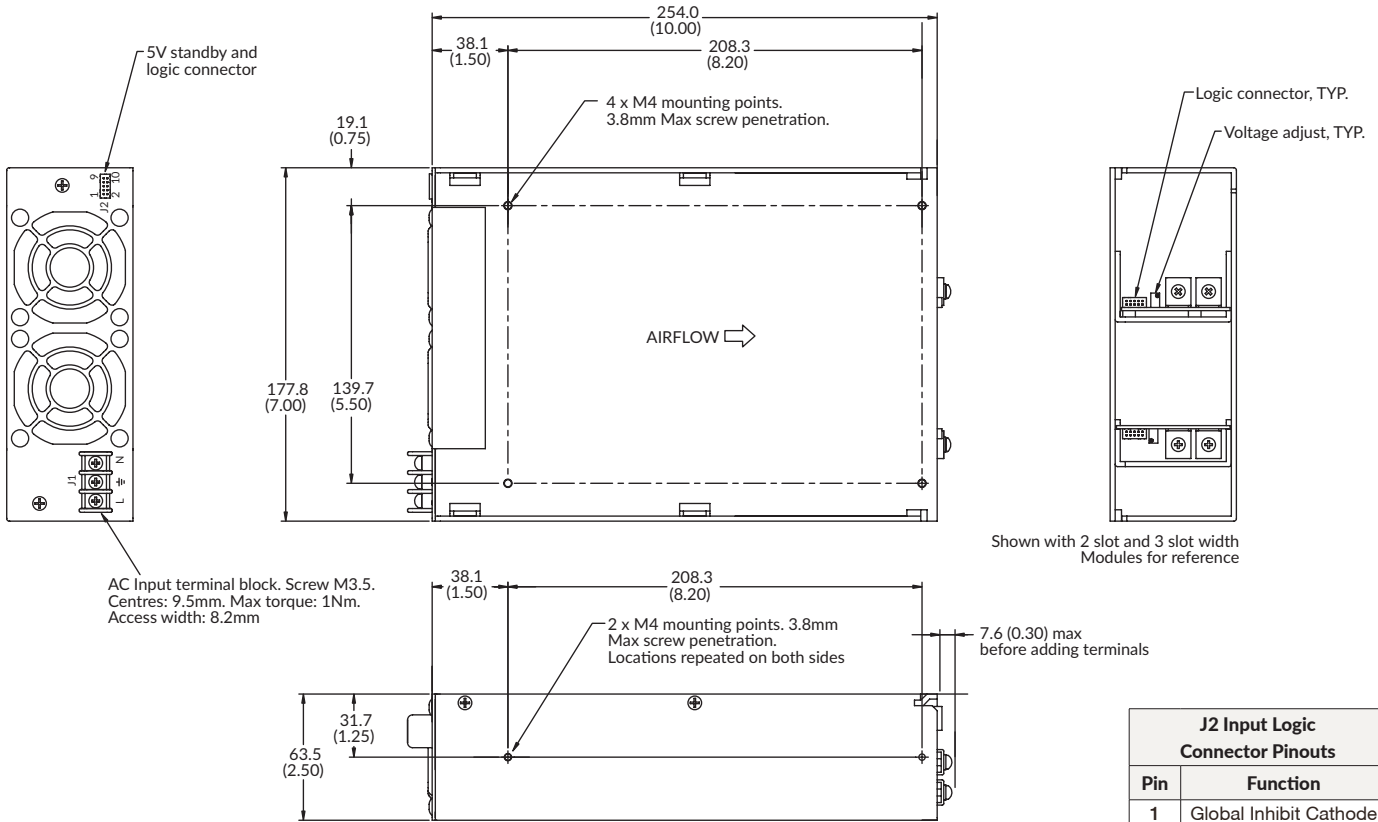

J2 Input Logic Connector Pinouts	
Pin	Function
1	Global Inhibit Cathode
2	Global Inhibit Anode
3	Global DC OK Emitter
4	Global DC OK Collector
5	Global AC OK Emitter
6	Global AC OK Collector
7	5V Standby
8	5V Standby Return
9	Manufacturer Use Only
10	Manufacturer Use Only

Notes:

1. All dimensions in mm (inches). Tolerance: x.xx (x.x) = ±0.5 (±0.02). x.xxx (x.xx) = ±0.25 (±0.01)
2. Mating plug: JST p/n PHDR-10VS.
3. Contact: 26-22 AWG JST p/n SPHD-001T-P0.5.
4. High line only (180-264VAC).
5. Weight: 1,800g (4lb) approx.

Mechanical Details

800 (1200)⁽⁴⁾ Watt X4DD & XM4DD Chassis, 1000 (1400)⁽⁴⁾ Watt X5DD & XM5DD Chassis, 1400 (1800)⁽⁴⁾ Watt X7DD & XM7DD Chassis

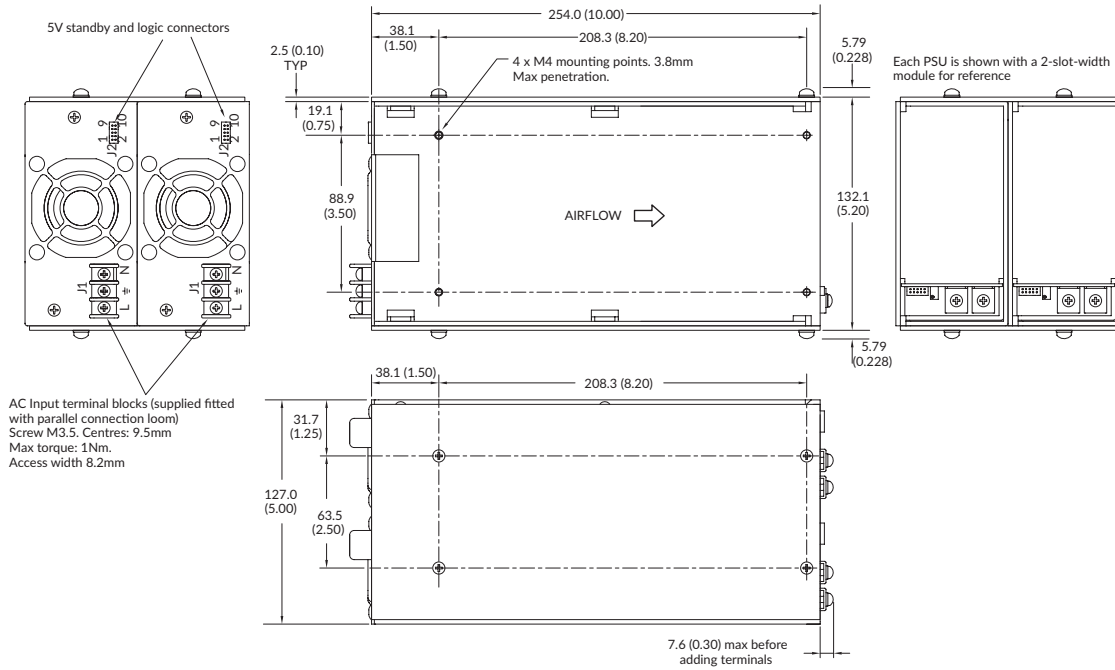

J2 Input Logic Connector Pinouts	
Pin	Function
1	Global Inhibit Cathode
2	Global Inhibit Anode
3	Global DC OK Emitter
4	Global DC OK Collector
5	Global AC OK Emitter
6	Global AC OK Collector
7	5V Standby
8	5V Standby Return
9	Manufacturer Use Only
10	Manufacturer Use Only

1800 (2200)⁽⁴⁾ Watt X9DD & XM9DD Chassis

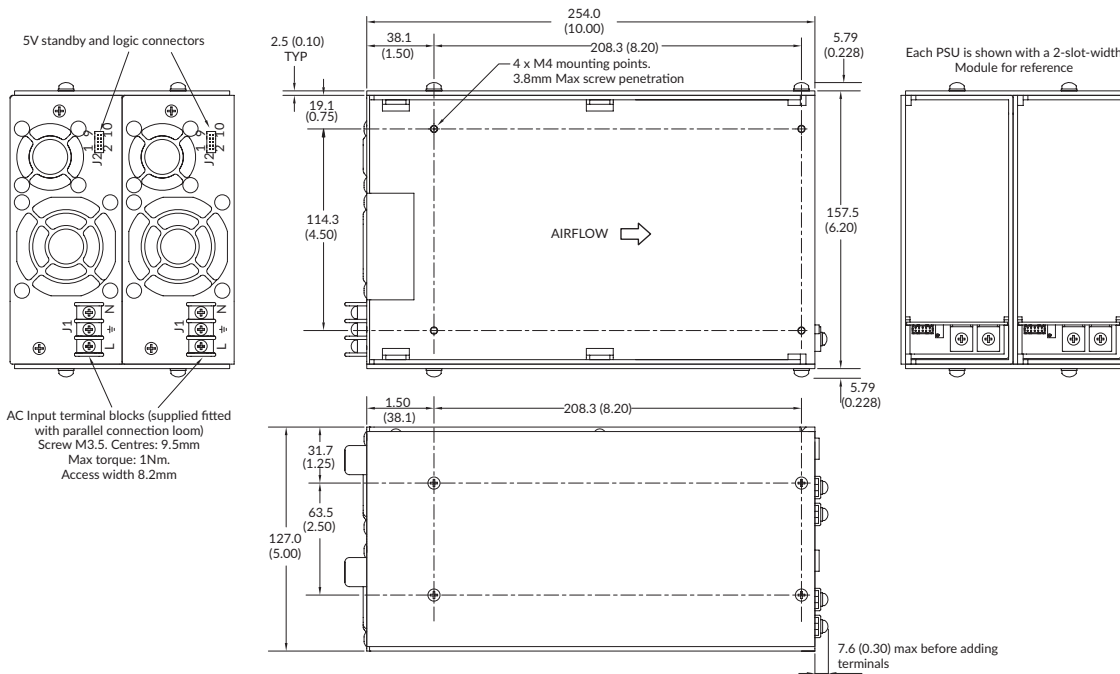

J2 Input Logic Connector Pinouts	
Pin	Function
1	Global Inhibit Cathode
2	Global Inhibit Anode
3	Global DC OK Emitter
4	Global DC OK Collector
5	Global AC OK Emitter
6	Global AC OK Collector
7	5V Standby
8	5V Standby Return
9	Manufacturer Use Only
10	Manufacturer Use Only

Notes:

- All dimensions in mm (inches).
Tolerance: x.xx (x.x) = ±0.5 (±0.02). x.xxx (x.xx) = ±0.25 (±0.01)
- Mating plug: JST p/n PHDR-10VS.
- Contact: 26-22 AWG JST p/n SPHD-001T-P0.5.
- High line only (180-264VAC).
- Weights: 800 (1200) W X4DD & XM4DD chassis: 2500g (5.5lbs) approx.
1000 (1400) W X5DD & XM5DD chassis: 2500g (5.5lbs) approx.
1400 (1800) W X7DD & XM7DD chassis: 2500g (5.5lbs) approx.
1800 (2200) W X9DD & XM9DD chassis: 3000g (6.6lbs) approx.

Mechanical Details

2000 (2400)(4) Watt X10DD & XM10DD Chassis

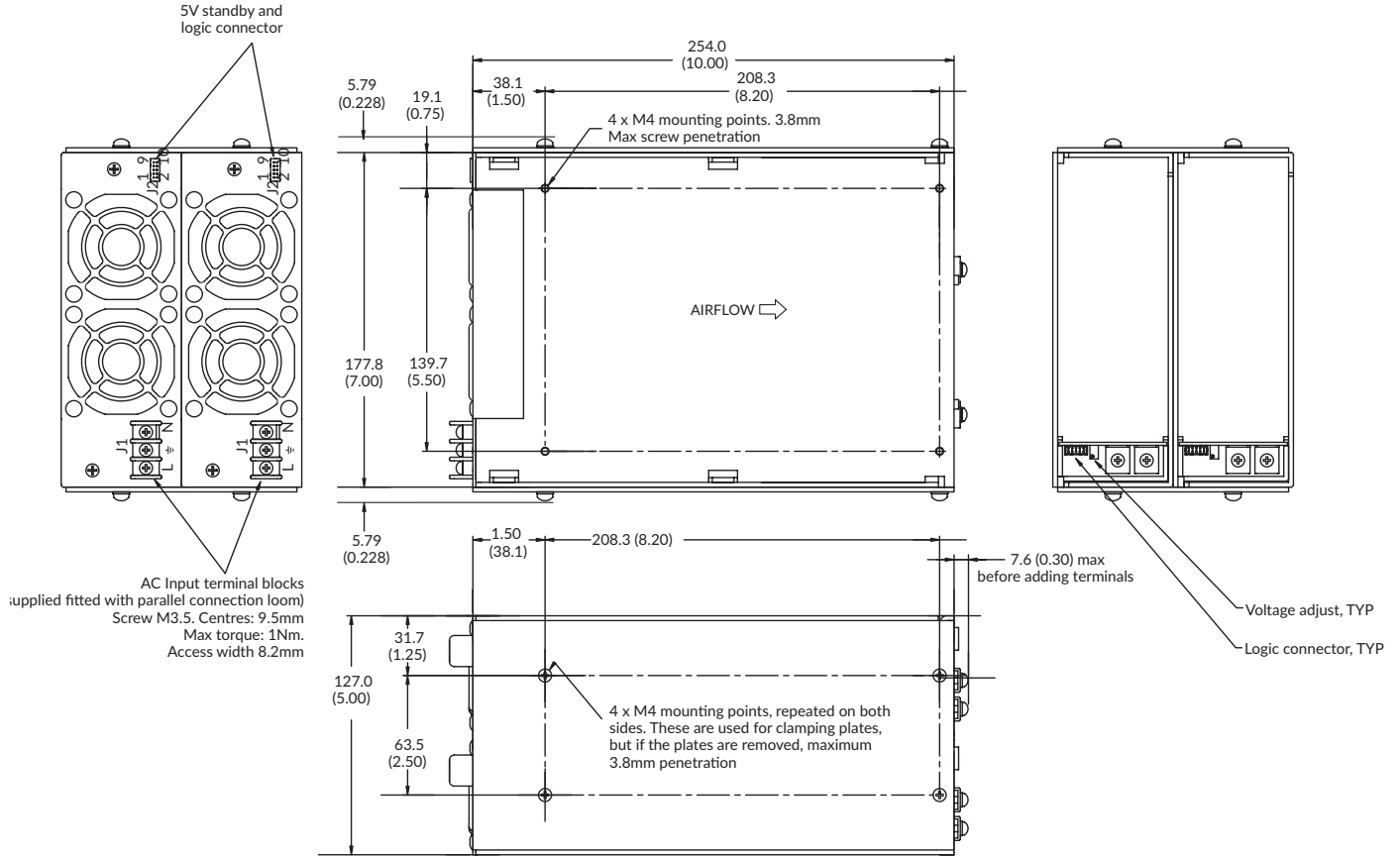

J2 Input Logic Connector Pinouts	
Pin	Function
1	Global Inhibit Cathode
2	Global Inhibit Anode
3	Global DC OK Emitter
4	Global DC OK Collector
5	Global AC OK Emitter
6	Global AC OK Collector
7	5V Standby
8	5V Standby Return
9	Manufacturer use only
10	Manufacturer use only

Notes:

- All dimensions in mm (inches).
Tolerance: x.xx (x.x) = ±0.5 (±0.02). x.xxx (x.xx) = ±0.25 (±0.01)
- Mating plug: JST p/n PHDR-10VS.
- Contact: 26-22 AWG JST p/n SPHD-001T-P0.5.
- High line only (180-264VAC).
- Weight: 3,636g (8.0lbs) approx.

1500 (2500)⁽⁴⁾ Watt X15 & XM15 Chassis

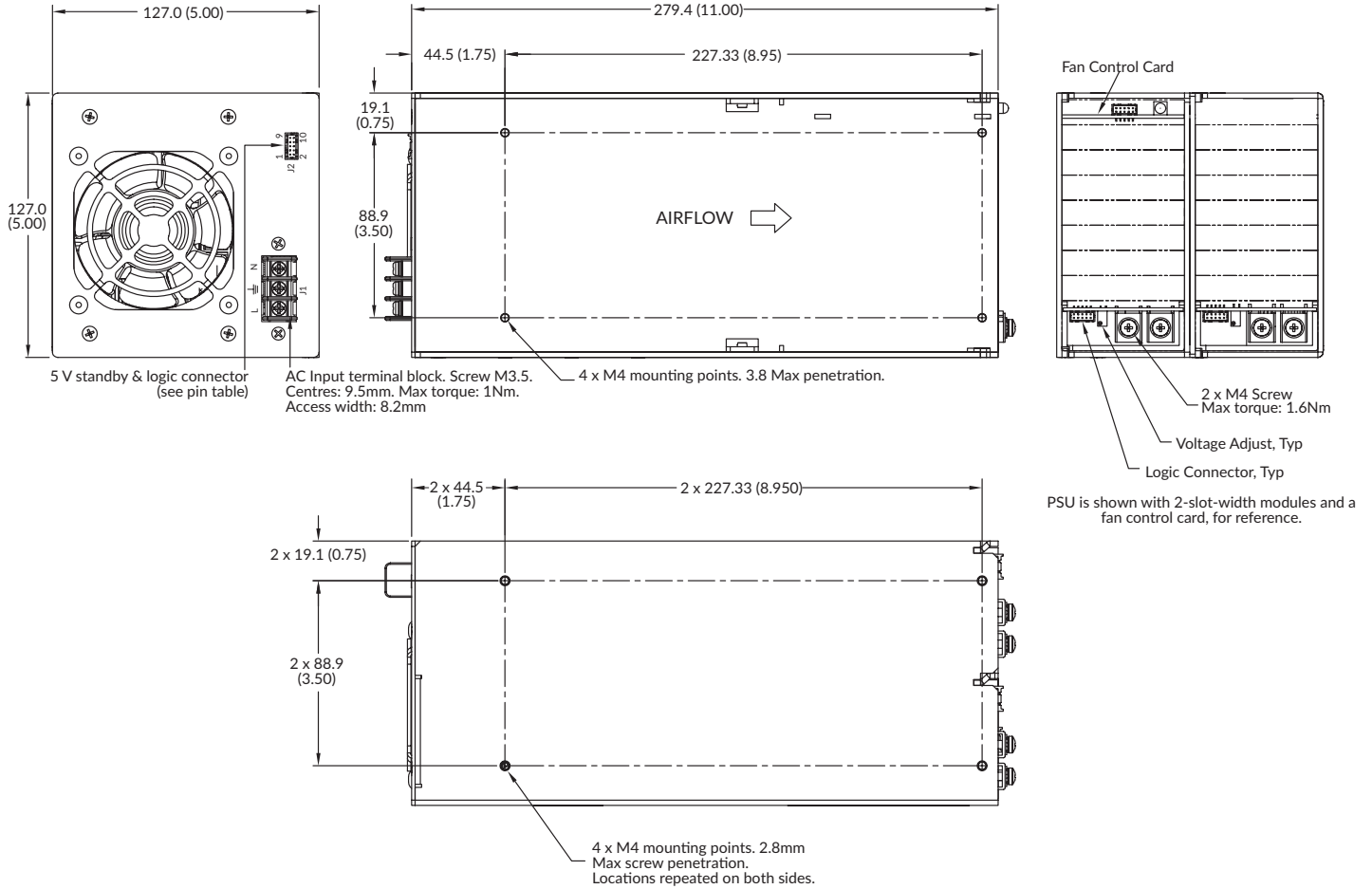

J2 Input Logic Connector Pinouts	
Pin	Function
1	Global Inhibit Cathode
2	Global Inhibit Anode
3	Global DC OK Emitter
4	Global DC OK Collector
5	Global AC OK Emitter
6	Global AC OK Collector
7	5V Standby
8	5V Standby Return
9	Manufacturer use only
10	Manufacturer use only

Notes:

- All dimensions in inches (mm).
Tolerance x.xx (x.x) = ± 0.5 (± 0.02). x.xxx (x.xx) = ± 0.25 (± 0.01)
- Mating plug: JST p/n PHDR-10VS.

- Contact: 26-22 AWG JST p/n SPHD-001T-P0.5.
- High line only (180-264VAC).
- Weight: 3.6kg (8.0lbs) approx.