

600W Baseplate cooled

AC-DC power supplies

A rugged, baseplate cooled AC-DC power supply in an enclosed chassis mount case with industrial & MIL-STD 461E EMC compliance, suitable for COTS applications. Robustly protected for overtemperature, overvoltage, overload and short circuit.

Features include a 5VDC 0.5A standby output, current sharing and remote monitoring for over temperature & power fail, an inhibit function also allows remote switching to control the output On/Off.

The baseplate cooling enables the CCH600 to operate in conditions requiring a sealed enclosure with the heat transferred out through the equipment casing.



Features

- ▶ 600W baseplate / conduction cooled
- ▶ Regulated single outputs 12 to 48VDC
- ▶ Input range 90 to 264VAC
- ▶ 214 x 102 mm footprint, 43mm profile
- ▶ High efficiency up to 90%
- ▶ Industrial & MIL STD461E EMC compliance
- ▶ Power Fail, inhibit, overtemp & current share
- ▶ 5VDC 0.5A standby
- ▶ -40°C to +70°C operation
- ▶ 3 year warranty

Applications



Dimensions

214 x 102 x 43 mm (8.43" x 4.02" x 1.69")

Documentation

For further information click the link or scan the code

→ xppower.com



Models & ratings

Model number	Output voltage V1	Output current V1	Standby output V2	Output power
CCH600PS12	12V	50.0A	5.0V/0.5A	603W
CCH600PS24	24V	25.0A		603W
CCH600PS28	28V	21.5A		603W
CCH600PS48	48V	12.5A		603W

Input

Characteristic	Minimum	Typical	Maximum	Units	Notes & conditions
Input voltage - operating	90	115/230	264	VAC	
Input frequency	47	50/60	63	Hz	
Power factor		>0.9			230VAC full load, EN61000-3-2 class A compliant
Input current - no load		0.4		A	
Input current - full load		6.3/3.1		A	115/230VAC
Inrush current			60	A	230VAC
Earth leakage current		0.7/1.1		mA	115/230VAC/50Hz (Typ.), 264VAC/60Hz (Max.)
		7.5/15.0			115/230VAC/400Hz
Input protection	F10 A/250V internal fuse				

Output

Characteristic	Minimum	Typical	Maximum	Units	Notes & conditions
Output voltage - V1	12		48	VDC	See models and ratings table
Initial set accuracy			$\pm 1^{(V1)}$ & $\pm 3^{(V2)}$	%	50% load, 115/230VAC
Output voltage adjustment			± 10	%	V1 only via potentiometer. See mechanical details
Minimum load	0			A	
Start up delay		1.0		s	230VAC full load.
Hold up time	20			ms	
Drift			± 0.2	%	After 20 min warm up
Line regulation			± 0.5	%	90-264VAC
Load regulation			$\pm 1^{(V1)}/\pm 5^{(V2)}$	%	0-100% load
Transient response			4	%	Recovery within 1% in less than 500 μ s for a 50-75% and 75-50% load step
Over/undershoot		1		%	
Ripple & noise		1		% pk-pk	20MHz bandwidth
Overvoltage protection	110		140	%	Vnom DC. Output 1, recycle input to reset
Overload protection	105		140	% I nom	Output 1, auto reset (see fig. 1)
Short circuit protection	Continuous, approx. constant current (see fig. 1)				
Temperature coefficient			0.05	%/°C	
Overtemperature protection			85	°C	Fitted to Baseplate

Output overload characteristic

Figure 1

Typical V1 overload characteristic (CCH600PS12)

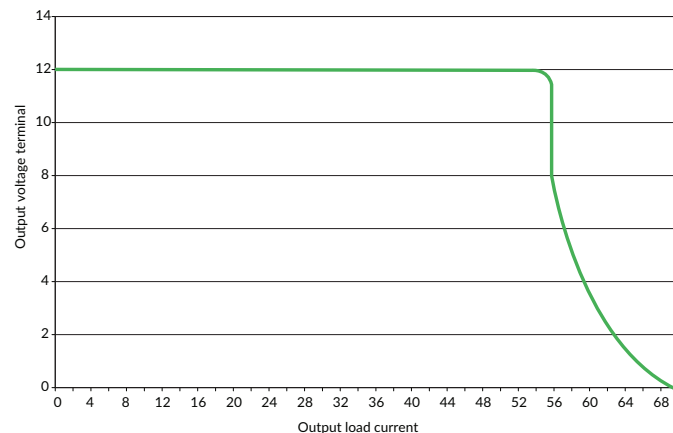

General

Characteristic	Minimum	Typical	Maximum	Units	Notes & conditions
Efficiency		89		%	230VAC, full load
Isolation: input to output input to ground output to ground	3000			VAC	
	1500			VAC	
	500			VDC	
Switching frequency		30-333		kHz	PFC converter, variable
		51.1			Main converter
		138			Standby converter
Power density			0.640 (10.5)	W/cm ³ (W/in ³)	
Mean time between failure		300		khrs	MIL-HDBK-217F, Notice 2 +25°C GB.
Weight		1.5 (3.3)		kg (lb)	

Environmental

Characteristic	Minimum	Typical	Maximum	Units	Notes & conditions
Operating temperature	-40		+85	°C	Baseplate temperature. See thermal considerations & performance, curve fig. 2.
Storage temperature	-40		+85	°C	
Cooling	Baseplate cooled				
Humidity	5		95	%RH	Non-condensing
Operating altitude			3000	m	
Shock	MIL-STD 810F clause 516.5 Proc 1. 40g, 11ms in 6axis				
Vibration	MIL-STD 810F figure 514.5C-17				

Temperature derating curve

Figure 2

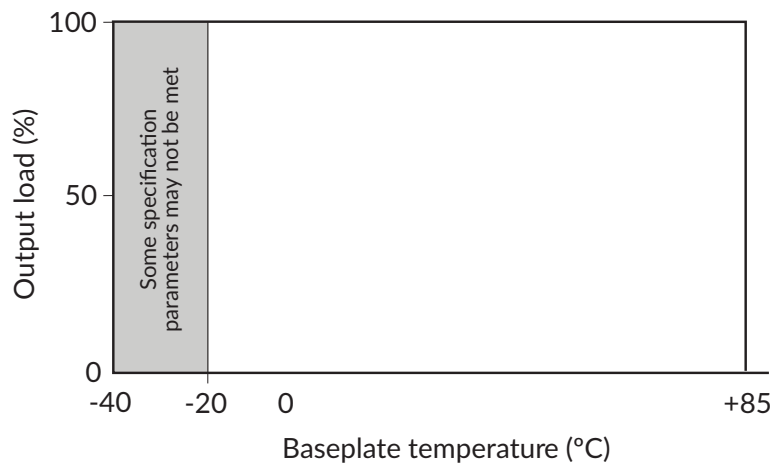

EMC: emissions

Phenomenon	Standard	Test level	Notes & conditions
Conducted	EN55032	Class B	
	MIL-STD-461E CE102	10KHz-10MHz	
Radiated	EN55022	Class A	
Harmonic currents	EN61000-3-2	Class A	
Voltage fluctuations	EN61000-3-3		

EMC: immunity

Phenomenon	Standard	Test level	Criteria	Notes & conditions
Low voltage PSU EMC	EN61204-3	High severity level	as below	
Radiated immunity	EN61000-4-3	3V/m	A	
EFT/burst	EN61000-4-4	3	A	
Surge	EN61000-4-5	Installation class 3	A	
Conducted	EN61000-4-6	3V	A	
	MIL-STD-461E CS114	Curve 3 10kHz - 200MHz		
Dips and interruptions	EN61000-4-11	Dip: 30%, 10ms	A	
		Dip: 60% 100ms	B	
		Int: 100% 5000ms	B	

Safety approvals

Certification	Standard	Notes & conditions
CB	IEC62368-1, IEC60650-1	Information technology
UL	UL62368-1 & CAN/CSA C22.2 No. 62368-1-14, UL60950-1, CSA C22.2 No. 60950-1-07 2nd Edition 2007-03	Information technology
TUV	EN62368-1:2014/A11:2017, EN60950-1	Information technology
CE	LVD	

Equipment protection class	Safety standard	Notes & conditions
Class I	IEC62368-1, IEC60950-1	See safety agency conditions of acceptability for details

Signals & controls

Characteristic	Notes & conditions
Remote sense	Compensates for 0.5V total voltage drop
AC OK / Power fail	Open collector referenced to output 0V, transistor on when AC is good (see fig. 3) AC OK: Provides ≥ 2 ms warning of loss of output from AC failure. Transistor on (<0.8 V) = AC OK. Transistor off (>4.5 V) = AC NOT OK.
Remote On/Off	The inhibit pin should be pulled below 0.4 V to switch V1 off. Open circuit or >4 V to switch output on.
Current share	Connecting pin 1 of like voltage units will force the current to share between the outputs. Units share current within 10% of each other at full load. See fig. 6.
Overtemperature warning	Open collector referenced to output 0V, transistor normally off when temperature is within safe limits.
Standby supply	5 V/0.5 A supply, always present when AC supplied. Isolated from the AC input, power output and auxiliary signals/controls.

AC OK / Power fail function

Figure 3

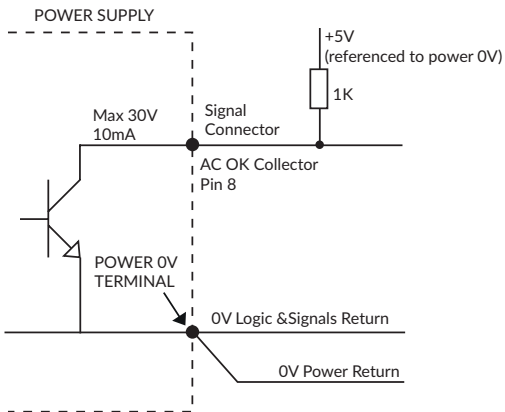

Ensure that the logic & signals return is run as a separate route and connected as close as possible to the PSU power OV terminal to avoid a voltage drop along the signal path

5V Standby to pull up open collector signal

Figure 4

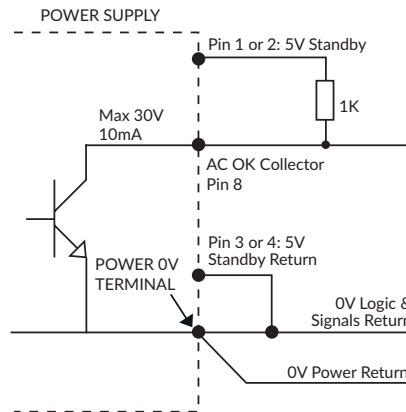

The 5V standby supply is a floating output. If required to 'pull-up' signal lines, the standby OV return must be connected to the OV power return.

Inhibit function

Figure 5

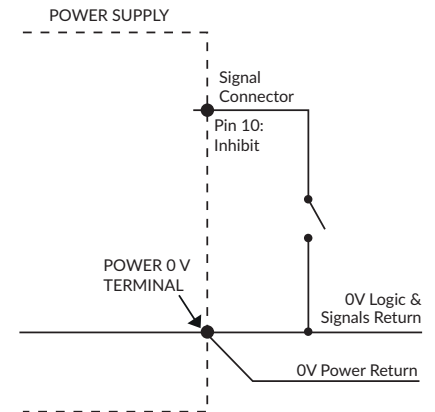

Parallel & current share

Figure 6

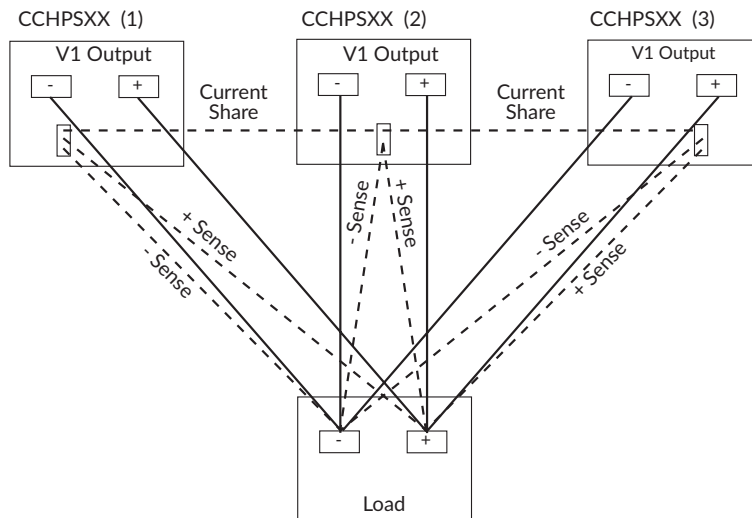

Mechanical details

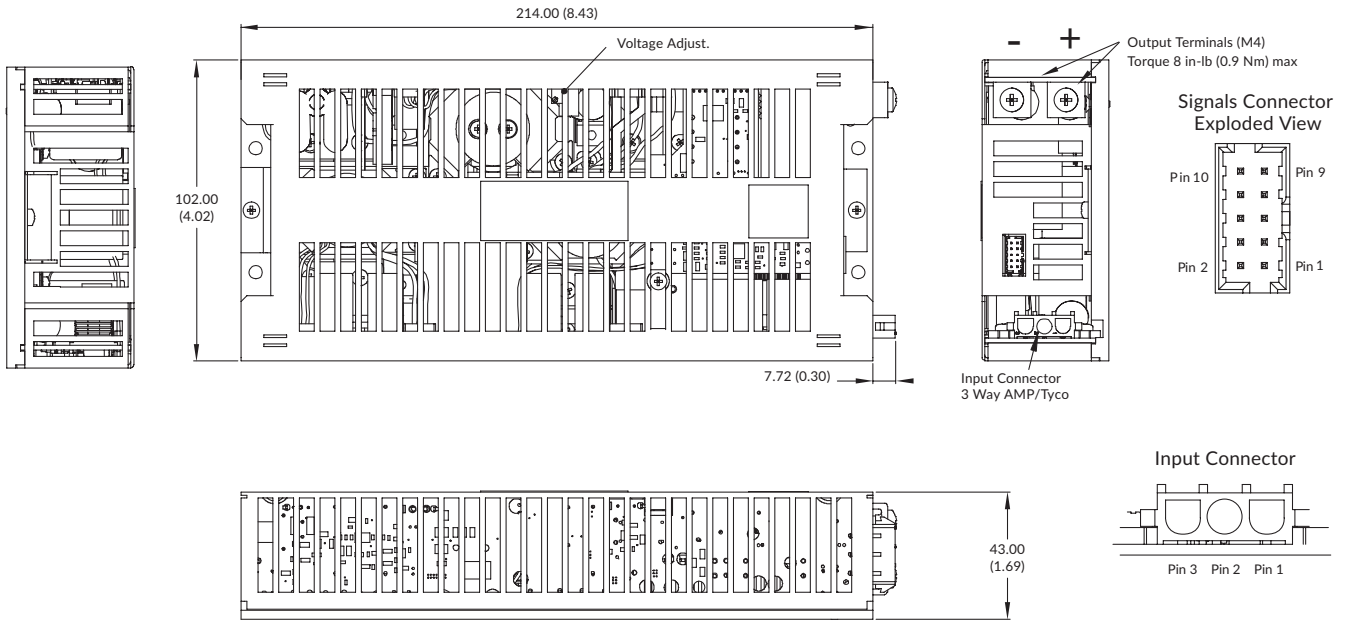

Mounting holes

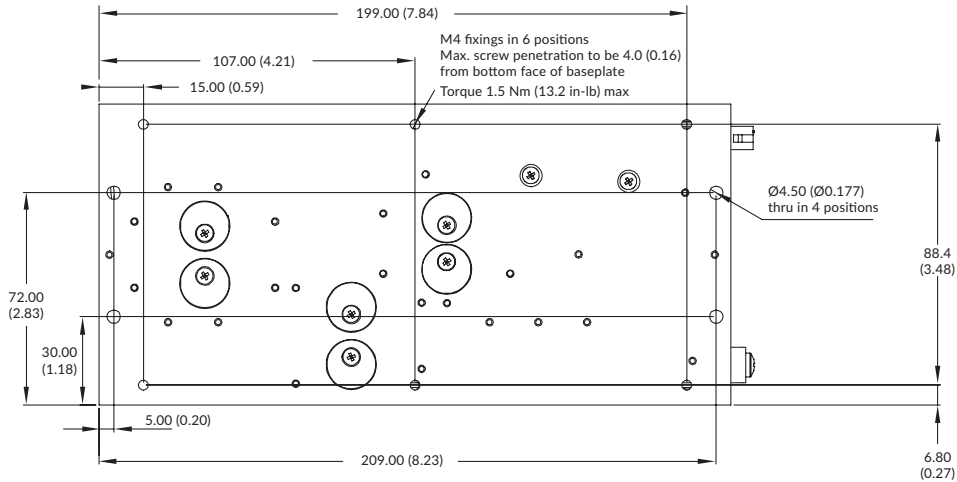

Input connector	
Pin 1	Earth
Pin 2	Neutral
Pin 3	Line

Connector: 3 way AMP/Tyco type MATE-N-LOK 1-350943-0
Mates with MATE-N-LOK 350766-1

Signal connector			
Pin 1	+Standby	Pin 6	-Sense
Pin 2	+Standby	Pin 7	Overtemperature warning
Pin 3	-Standby	Pin 8	Power fail
Pin 4	-Standby	Pin 9	Current Share
Pin 5	+Sense	Pin 10	Inhibit

Connector: 10 WAY 2mm pitch p/n MOLEX 87833-1031
Mating half: p/n MOLEX 51110-1056
Contact: p/n MOLEX 50394-8100

Notes:

- All dimensions shown in mm (inches).
- Tolerance x.xx = 0.50 (0.02); x.xxx = 0.25 (0.01)
- Weight 1.5kg (3.3lbs)
- Connector kit available, order part no. 'CCH CONKIT'
- Inhibit, overtemperature and power fail are referenced to the 0V power terminal

Efficiency graphs

Efficiency vs Load

Figure 7

CCH600PS12

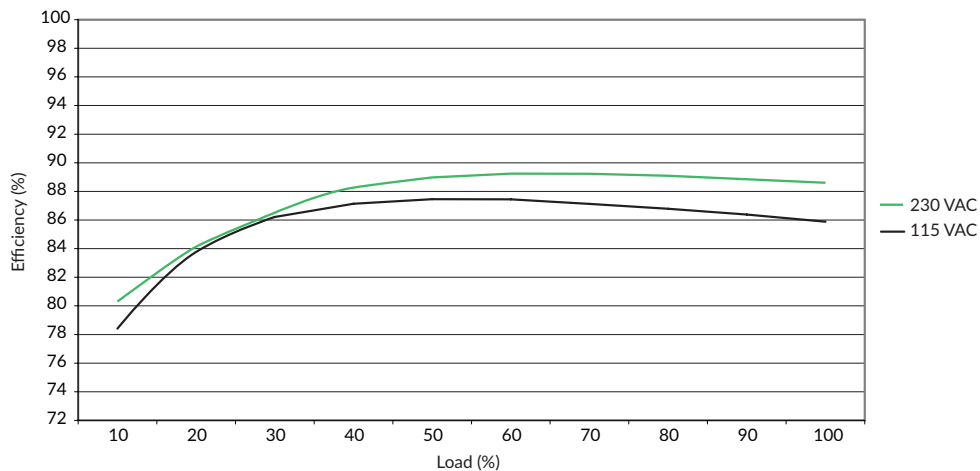
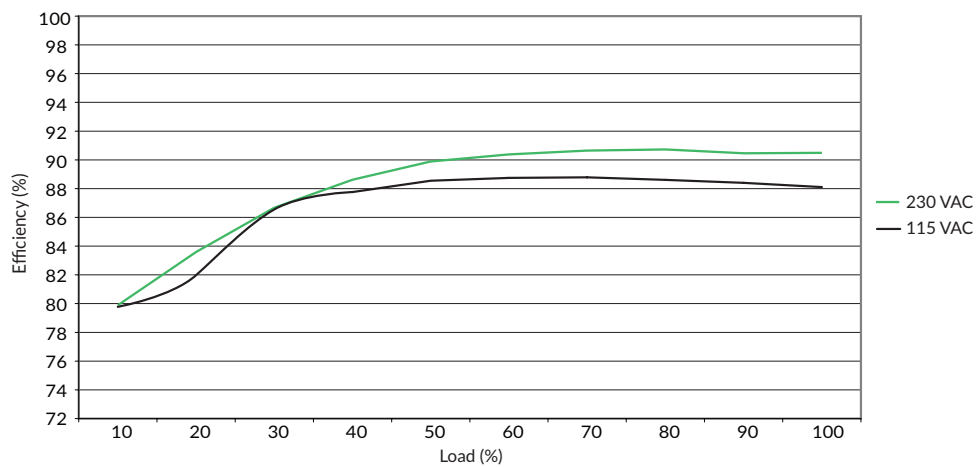

Figure 8

CCH600PS48



Thermal considerations

Baseplate cooling

The use of power supplies in harsh or remote environments brings with it many fundamental design issues that must be fully understood if long-term reliability is to be attained.

Under these conditions, it is generally accepted that electronic systems have to be sealed against the elements. This makes the removal of unwanted heat particularly difficult. The use of forced-air cooling is undesirable as it increases system size, adds the maintenance issues of cleaning or replacing filters, and the fan being prone to wear out, particularly in tough environments.

The extremes of ambient temperature encountered in remote sites can range from -40°C to over $+40^{\circ}\text{C}$. It is common for the temperature within the enclosure to rise some 15 to 20°C above the external temperature. The positioning of the power supply within the enclosure can help minimize the ambient temperature in which it operates and this can have a dramatic effect on system reliability.

System enclosures are typically sealed to IP65, IP66 or NEMA 4 standards to prevent ingress of dust or water. Removal of heat from other electronic equipment and power supplies in a situation with negligible airflow is the challenge. From the power system perspective, the most effective solution is to remove the heat using a heatsink that is external to the enclosure. However, most standard power supplies cannot provide an adequate thermal path between the heat-dissipating components within the unit and the external environment.

Fundamentally, the successful design of a power supply for use within sealed enclosures relies on creating a path with low thermal resistance through which conducted heat can be passed from heat-generating components to the outside world.

The components that generate the most heat in a power supply are distributed throughout the design, from input to output. They include the power FET used in an active PFC circuit, the PFC inductor, power transformers, rectifiers, and power switches. Heat can be removed from these components by thermally connecting them to the baseplate that in turn can be affixed to a heatsink. As mentioned earlier, the heatsink is then located outside of the enclosure.

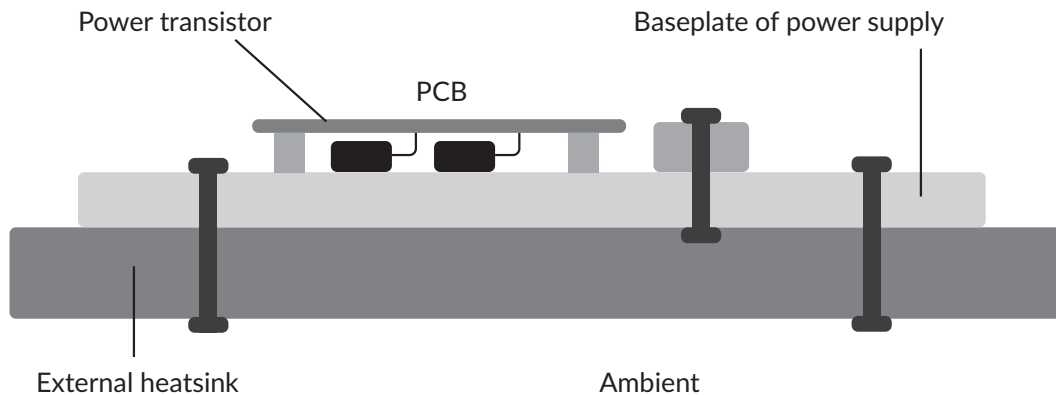

Dissipating the heat: Heatsink Calculations

Three basic mechanisms contribute to heat dissipation: conduction, radiation and convection. All mechanisms are active to some degree but once heat is transferred from the baseplate to the heatsink by conduction, free convection is the dominant one.

Effective conduction between the baseplate and heatsink demands flat surfaces in order to achieve low thermal resistance. Heat transfer can be maximized by the use of a thermal compound that fills any irregularities on the surfaces. System designers should aim to keep thermal resistance between baseplate and heatsink to below $0.1^{\circ}\text{C}/\text{W}$. This is the performance offered by most commonly used thermal compounds when applied in accordance with manufacturers' instructions.

Radiation accounts for less than 10% of heat dissipation and precise calculations are complex. In any case, it is good practice to consider this 10% to be a safety margin.

Thermal considerations

The following example shows how to calculate the heatsink required for an CCH600PS48 with 230VAC input and an output load of 500W operating in a +40°C outside ambient temperature.

1. Calculate the power dissipated as waste heat from the power supply. The efficiency (see fig. 7 and 8) and worst case load figures are used to determine this using the formula:

$$\text{Waste heat} = \left\{ \frac{1 - \text{Eff}\%}{\text{Eff}\%} \right\} \times P_{\text{out}} = \left\{ \frac{1 - 0.91}{0.91} \right\} \times 500\text{W} = 49.5\text{W}$$

2. Estimate the impedance of the thermal interface between the power supply baseplate and the heatsink. This is typically 0.1°C/W when using a thermal compound.
3. Calculate the maximum allowable temperature rise on the baseplate. The allowable temperature rise is simply:

$$T_B - T_A \text{ where } T_A \text{ is the maximum ambient temperature outside of the cabinet}$$

$$\text{and } T_B \text{ is the maximum allowable baseplate temperature.}$$

4. The required heatsink is defined by its thermal impedance using the formula:

$$\theta_H = \frac{T_B - T_A}{\text{Waste Power}} - 0.1 = \frac{85^\circ\text{C} - 40^\circ\text{C}}{49.5\text{W}} - 0.1 = 0.81^\circ\text{C/W}$$

5. The final choice is then based on the best physical design of heatsink for the application that can deliver the required thermal impedance. The system's construction will determine the maximum available area for contact with the baseplate of the power supply and the available space outside of the enclosure will then determine the size, number and arrangement of cooling fins on the heatsink to meet the dissipation requirement.