

Isolated Analog Programming / Interface

Interface to the operating instructions
(Translated from German)

Contents

	Page
1 Analog Programming option / interface.....	2
1.1 General.....	2
1.2 Foreseeable misuse when using analog programming.....	3
1.3 Overview of analog programming	4
1.4 Wiring options.....	5
1.5 Operation of the analog interface	6

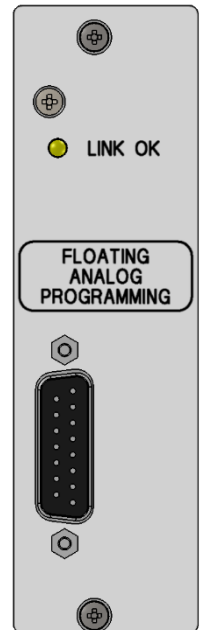

This manual was created by: XP Power FuG, Am Eschengrund 11, D-83135 Schechen, German

1. Analog Programming option / interface

1.1. General

The analog interface (15-pole Sub-D socket on the rear panel) is used to control the functions voltage setting, current setting as well as OUTPUT ON/OFF and special functions, depending on the unit type. The current actual values are provided as analog voltages and the latest control modes as digital signals.

The assignment of some pins differs depending on the device series. Please refer to the overview for analog programming under 1.3.

The interface is located on the rear panel of the DC power supply.

Isolation

All signals are 2 kV isolated from the output potential via fibre optic.

With isolated analog programming there is no galvanic connection between the pins of the programming interface and the output sockets.

Function

Voltage and current values can be set with normalized analog signals (external reference). The internal reference voltage +10 V can be tapped at pin 10 and used to generate these setpoint signals (e.g. with 10 k Ω potentiometers), see wiring options under 1.4

Signal and control cable

The analog interface is implemented via a shielded Sub-D socket. The shield is connected to the housing potential (PE). The mating connector, as well as the data link, must be shielded and the shields must be connected to each other. The maximum permissible length of the shielded cable is 3m. These are requirements for compliance with electromagnetic compatibility (EMC), see also the Declaration of Conformity in the appendix.

Voltage limitation

The voltage limitation, if present adjustable by the potentiometer VLIMIT on the front panel of the DC power supply, is still active.

1.2. Foreseeable misuse when using analog programming

WARNING

Danger of electrical shock at the power outputs!



If the device is operating in **ANALOG** mode and the analog programming interface cable is pulled the output voltage drops to 0V after the unloading time which depends on the connected load. Once the analog programming interface cable is plugged in again without changing the remote control settings, the last set values will be present at the outputs.

1.3. Overview of analog programming:

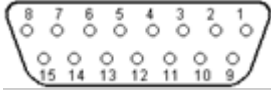
View of solder side plug  plug connection			
Pin	Description	Type	Function
1	CC	DO	supplies approx. +15 V, if power supply is in constant current mode, equivalent to LED CC, Ri approx. 10 K Ω
2	CV	DO	supplies approx. +15 V, if power supply is in voltage mode, equivalent to LED CV, Ri approx. 10 K Ω
3	I-MON	AO	actual output current monitor signal 0...10 V, represents 0...I _{nominal} , Ri approx. 11 K Ω
4	Not used		
5	Not used		
6	OVD	D GND	ground for digital signals, may be current loaded.
7	Not used		for devices of the HCB, MCA, MCP, NLN, NTN series without function.
	POL-SET	DI	control input for electronic polarity reversal switch (Option) POS = pin (7) open, NEG = connected to Pin (6) OVD
	V/I REG	DI	switchover voltage/current regulation only applies to the NLB series V-REG mode: connect Pin7 with Pin6 (Pin7=0), I-REG mode: Pin7 unconnected
8	V-SET	AI	0...+10 V equals 0...U _{nominal} , input resistance to 0V approx. 10 M Ω
9	0V	A-GND	ground for analog signals, must not carry any current
10	+10VREF	AO	+10 V Reference (output), max. 2 mA
11	V-MON	AO	actual output voltage monitor signal 0...10 V represents 0...U _{nominal} ; Ri approx. 11 K Ω
12	OUTPUT ON	DI	Pin (12) open = OUTPUT OFF, Pin (12) connected to OVD Pin (6) = OUTPUT ON
13	Not used		for devices of the MCP, NLN series without function.
	POL-Status	DO	polarity status (option) applies to devices with polarity reversal switch. POS polarity = approx. +12 V, NEG polarity = 0 V
	-10V REF	AO	for the devices of the HCB, NLB series
	P-LIM	DO	delivers approx. +15 V, when the MCA series device is driven into power limit, equivalent to LED P-LIM on the front panel
	S-REG	DO	Delivers approx. +15 V, if NTN series device in SENSE control (only with active sensor operation), equivalent to LED S-ERR on front panel.
14	Not used		
15	Not used		for devices of the HCB series
	I-SET	AI	0...+10 V equals 0...I _{nominal} , input resistance against 0 V approx. 10 M Ω

All values of voltages and currents are in DC.
D=Digital, A=Analog, I=Input, O=Output
Pay attention to your unit type and options in the coloured lines.

1.4. Wiring options

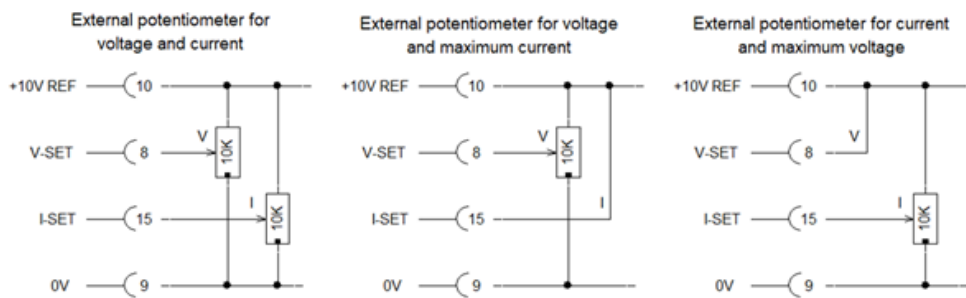
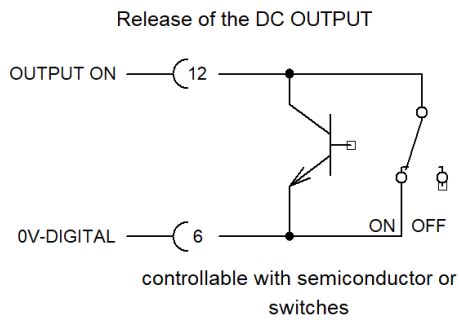

1.5. Operation of the analog interface

WARNING

Enable of OUTPUT ON/OFF

The DC OUTPUT is switched on by connecting pin 12 to pin 6, see 1.4

If the DC OUTPUT is switched on with a wire connection between pin 12 and pin 6, the OUTPUT remains active until the connection between pin 12 and pin 6 is open or the mains is switched off.

In the event of a mains voltage failure, the DC OUTPUT remains enabled. As soon as the mains voltage is supplied again, the DC OUTPUT is active again!



Electric shock possible due to residual voltage at the output!

When the unit is switched off or in the event of a power failure, residual voltage / current will NOT be displayed on the monitor outputs!

Observe the discharge time!

Putting the analog programming option / interface into operation



1. The installation of the analog interface has to be executed when the DC power supply is not in operation!
 2. The interface of the control unit shall be connected to the interface of the DC power supply as specified.
 3. Now turn on the POWER switch (1).
 4. Select the ANALOG operating mode with the switch or switches. The ANALOG LED now lights up.
- The device is now operated externally via the programming socket!

To switch the power supply off, proceed as follows:

1. Set the values at the pin (8) V-SET and pin (15) I-SET to 0V.
 2. Open the connection between Pin 12 and 6.
 3. After the output voltage has reached a value < 50 V, switch the device completely off using the POWER switch.
- The DC power supply is switched off.