

Charge power 400J/s Bench mount/ rack mount

AC-HVDC
capacitor chargers

The HCK400 series are stable DC power supplies, designed specially to meet the requirements of capacitor charging and capacitor conditioning. They feature a robust output resistor to be able to withstand the demands of a pulsed load. The control circuit is designed for fast transitions from constant current to constant voltage operation.

The equipment is suitable for both continuous and pulsed charging, this is achieved using an adjustable constant current without overshoot. Capacitors with a resistive component are also suitable as loads. Usually, an external protective resistor is not required. It is, however, recommended for applications with very high levels of stored energy.

The specified maximum charging power is achieved when charging from zero volt (0) to the rated voltage. The HCK series can operate in circuits where the load capacitor is fully discharged with each pulse, or in circuits where the load capacitor is only partially discharged with each pulse. The charging process can either be continuous or triggered using the external trigger input.

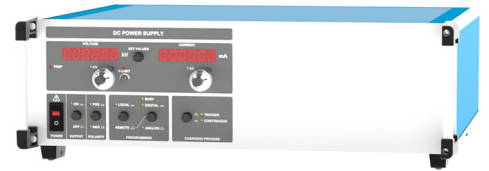

Features

- ▶ Output voltages 0-2kVDC to 0-65kVDC
- ▶ Single phase AC input
- ▶ Suitable for continuous or trickle charging
- ▶ Continuous or external triggered charging mode selectable
- ▶ Charging takes place with adjustable constant current without overshooting
- ▶ End of charge signal, when the final voltage is reached via LED and potential-free contact
- ▶ Repetition frequency typical <10Hz
- ▶ Multi-function control panel with user friendly interface
- ▶ Digital and/or analog interface option
- ▶ Manual voltage and current control with digital display
- ▶ Set-point display via a button
- ▶ Set-point adjustment possible with disabled output
- ▶ Push-button switch for output voltage
- ▶ Adjustable overvoltage limit
- ▶ CE marked, EN61010-1 safety compliant
- ▶ Short circuit & arc protection
- ▶ 2 year warranty

Benefits

- ▶ Provides maximum device control & flexibility
- ▶ Safe operation ensures maximum protection to the power supply
- ▶ High voltage release included for safe operation at high voltage output
- ▶ User friendly controls combined with simple terminal software gives greater flexibility
- ▶ Special solutions are available, visit our [more resources](#) section to see our full range of options

Applications



- ▶ Capacitor charging
- ▶ Capacitor conditioning
- ▶ Particle accelerator
- ▶ Pulsed applications
- ▶ Material crushing
- ▶ Cable testing
- ▶ Electromagnetic fields
- ▶ Renewable energy

Dimensions

Click the link to the dimensions table

→ [mechanical details](#)

More resources

Click the link or scan the code

→ xppower.com



Models & ratings

Model number	Polarity	Output voltage	Output current	Input voltage	Frequency	Connectors	HV-cable
HCK2.0P400S	Positive	0 to +2kV	0 to 400mA	230VAC, ±10%	47 to 63Hz	SHV-10	RG58
HCK2.0N400S	Negative	0 to -2kV					
HCK2.0R400S	Reversible	0 to 2kV					
HCK3.5P200S	Positive	0 to +3.5kV	0 to 200mA	230VAC, ±10%	47 to 63Hz	F3415	130 660
HCK3.5N400S	Negative	0 to -3.5kV					
HCK3.5R200S	Reversible	0 to 3.5kV					
HCK6.5P120S	Positive	0 to +6.5kV	0 to 120mA	230VAC, ±10%	47 to 63Hz	F3415	130 660
HCK6.5N120S	Negative	0 to -6.5kV					
HCK6.5R120S	Reversible	0 to 6.5kV					
HCK012P060S	Positive	0 to +12.5kV	0 to 60mA	230VAC, ±10%	47 to 63Hz	F3430	RG11
HCK012N060S	Negative	0 to -12.5kV					
HCK012R060S	Reversible	0 to 12.5kV					
HCK020P040S	Positive	0 to +20kV	0 to 40mA	230VAC, ±10%	47 to 63Hz	KS150	C2032 SVJ
HCK020N040S	Negative	0 to -20kV					
HCK020R040S	Reversible	0 to 20kV					
HCK035P020S	Positive	0 to +35kV	0 to 20mA	230VAC, ±10%	47 to 63Hz	KS160	C2124
HCK035N020S	Negative	0 to -35kV					
HCK035R020S	Reversible	0 to 35kV					
HCK065P012S	Positive	0 to +65kV	0 to 12mA	230VAC, ±10%	47 to 63Hz	KS160	C2124
HCK065N012S	Negative	0 to -65kV					
HCK065R012S	Reversible	0 to 65kV					

Notes:

1. For further information, please refer to the [cables & connectors](#) guide.

Options

- ▶ Analog programming/interface
- ▶ Analog programming/interface, floating
- ▶ Computer interfaces IEEE 488, RS 232, RS 422, RS 485, Profibus, USB, LAN (more on request)
- ▶ Repetition Frequency up to 100Hz

For further information about options and special solutions, please click on any of the links below:

Special solutions & modifications

→ [view options](#)

Analog programming & interfaces

→ [view options](#)

Digital programming & interfaces

→ [view options](#)

Or consult XP Power Sales directly.

Input

Characteristic	Minimum	Typical	Maximum	Units	Notes & conditions
Input voltage	See models and ratings table				
Efficiency		90		%	
Oversvoltage category		II			
Protection class		I			
Input connector	IEC 60320-1 C14 receptacle				
Input cable	Single phase mains: with CEE-7/7				

Output

Characteristic	
Output voltage range	See models and ratings table
Output current range	See models and ratings table
Output control	Continuous adjustment from 0 to rated voltage/current by front panel mounted potentiometers
Output polarity	See models and ratings table
Output isolation	"OV" terminal is connected to the PE (EARTH) but may be disconnected as needed. Current return preferably takes place via the screen of the output cable
HV output connection	Mating HV connector and 3m cable supplied
Voltage setting range	With the VOLTAGE ten-turn potentiometer, approx. 0.1% to 100% of the rated value (stable operation from 1%)
Current setting range	With the CURRENT ten-turn potentiometer, approx. 0.1% to 100% of the rated value (stable operation from 1%)
Set point resolution	$\pm 1 \times 10^{-3}$ of rated value with potentiometer on front panel $\pm 1 \times 10^{-5}$ of rated value with option fine potentiometer with option interface 16-bit resolution incl. sign bit (max. 22bit)
Residual ripple of charging current	Max. 10% pp of the rated value (measuring bandwidth 30 Hz to 10 MHz)
Accuracy	Voltage: $\pm 0.2\%$ of the nominal value Current: within the range of >5mA up to <200A: $\pm 0.2\%$ of the nominal value Outside the above mentioned range: $\pm 0.5\%$ of the nominal value Additional digital display error ± 2 digits
Charge voltage reproducibility	$\pm 10\%$ mains voltage variation: $\pm 1 \times 10^{-4}$ of rated value Over 8h: $\pm 1 \times 10^{-3}$ of rated value in temperature change of $\pm 2 \times 10^{-4}$/K At repetition frequency of <math>< 10\text{Hz}</math>: $\pm 1 \times 10^{-3}$ of rated value At repetition frequency of >10Hz: $\pm 1 \times 10^{-2}$ of rated value
Short circuit protection	The power supply is short-circuit and flash-over proof. The maximum current can be drawn at any output voltage even at short-circuit.
Repetition frequency	typically <math>< 10\text{ Hz}</math>, up to 100 Hz on request

Environmental

Characteristic	Minimum	Typical	Maximum	Units	Notes & conditions
Temperature operation	0		+40	°C	
Storage temperature	-20		+50	°C	
Humidity - operation			+80	%	Up to +31°C, decreasing linearly down to 50% RH at 40°C
Humidity - storage			+80	%	No precipitation, dust-free and dry
Operating altitude			2000	m	Above sea level
Pollution degree		1			
Ingress protection	IP20				
Operation location	Only for use in dry indoor areas				

Signals & controls

	Function
Front panel	Voltage and current potentiometer, power switch, HV ON/OFF switch, digital display for current and voltage, voltage limit potentiometer. Display of the output voltage and current set points is possible with the VIEW SET push-button. Charging mode selectable via front switch, feedback via LED.
Operating modes	A continuous or external triggered charging mode can be selected. External charging control with potential free trigger input and "Charge Complete" output via optokoppler (details on page 7). The power supplies can be operated in the LOCAL, ANALOG (optional) and DIGITAL (optional) operating modes.

EMC: immunity & emissions

Phenomenon	Standard	Notes & conditions
Immunity	EN61000-6-1	Standard for residential, commercial and light-industrial environments
Emissions	EN61000-6-3	Standard for equipment in residential environments

Safety approvals

Safety agency	Safety standard	Notes & conditions
EN	EN61010-1	
CE	Meets all applicable directives	

Mechanical details

Front view with controls

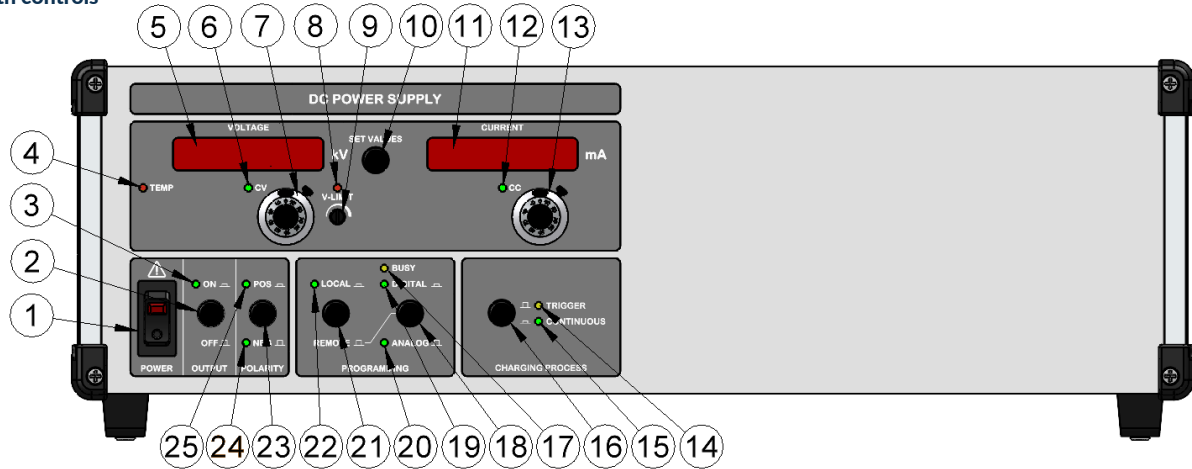

Example: HCK with dimensions: width 19"/443mm; height 3U/133mm

Front panel shown for illustrative purposes only, dimensions and layout differ by power rating - see mechanical details table.

Number	Function	Number	Function
1	POWER switch (AC) with indicator light: Disconnects the power supply from the mains, two-pole switching.	14	TRIGGER LED: Illuminated yellow indicating the external TRIGGER charging progress is active.
2	OUTPUT switch (DC). There is no mains disconnection!	15	LED CONTINUOUS: Illuminated green indicating the CONTINUOUS charging progress is active.
3	ON LED: DC output ON. Illuminated green when the controller and power stage are ON.	16	CHARGING PROCESS switch: adjustment for charging mode CONTINUOUS or via external TRIGGER.
4	TEMP LED: Illuminated red indicating overtemperature. Internal temperature too high, fan failed or airflow blocked.	17	BUSY LED: Illuminated yellow indicating data traffic on the digital interface. (Optional)
5	VOLTAGE display: Indicating actual value. Displays set point when flashing.	18	DIGITAL/ANALOG operation mode switch: Switches between REMOTE/ANALOG mode and REMOTE/DIGITAL mode. (Optional)
6	CV LED: Illuminated green indicating constant voltage mode.	19	DIGITAL LED: Illuminated green indicating digital programming active. (Optional)
7	Voltage adjustment: Ten-turn potentiometer with lockable precision dial.	20	ANALOG LED: Illuminated green indicating analog programming active. (Optional)
8	V-LIMIT LED for active voltage set-point limit.	21	LOCAL/REMOTE operation mode switch: Switches between LOCAL mode and REMOTE mode. (Optional)
9	V-LIMIT Set-point limitation adjustment for voltage (can only be operated with a screwdriver).	22	LOCAL LED: Illuminated green indicating LOCAL control mode active. (Optional)
10	SET VALUES switch: Switches displays between actual value and set value.	23	POLARITY switch: Local output polarity adjustment (Optional) Without polarity reversal, polarity labelled using coloured stickers: RED: POSITIVE; BLUE: NEGATIVE
11	CURRENT display: Indicating actual value. Displays set point when flashing.	24	NEG LED set for negative output voltage. (Optional reverse polarity switch)
12	CC LED: Illuminated green indicating constant current control mode.	25	POS LED set for positive output voltage. (Optional reverse polarity switch)
13	Current adjustment: Ten-turn potentiometer with lockable precision dial.		

Mechanical details

Rear view with single phase AC input

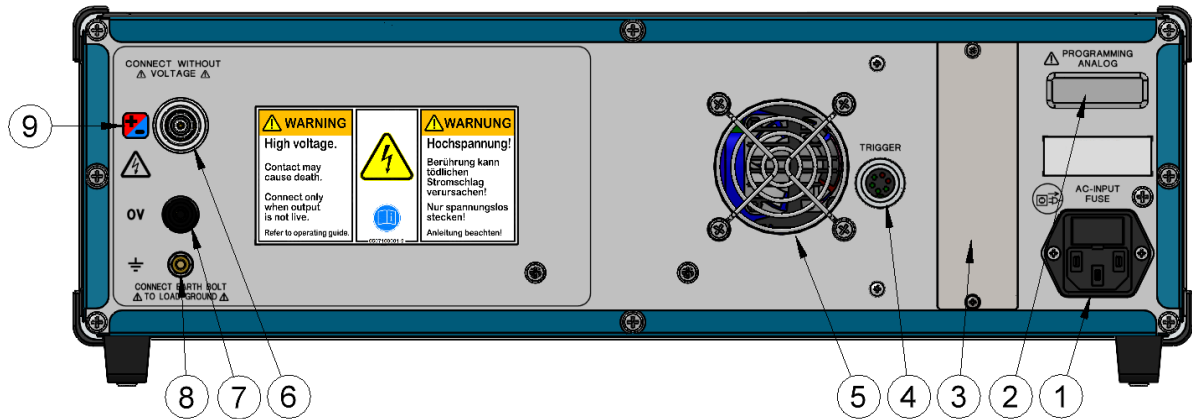

Example: HCK with polarity reversal and dimension: width 19"/443mm; height 3U/133mm

Rear panel shown for illustrative purposes only, dimensions and layout differ by power rating - see mechanical details table.

Number	Function	Number	Function
1	AC input: IEC connector (as shown) with integrated fuse.	6	HV output: dedicated for screened HV-cable with grounded shield, which can be used for current return.
2	15-pin Sub-D connector for analogue programming. (Optional)	7	0V load connection: internally connected to the 0V of the electronics. Is permanently connected to the protective conductor (PE).
3	Slot for digital interface (e.g.: IEEE-488, RS232, USB, LAN, ...). (Optional)	8	Earth connection: is permanently connected to the protective earth (PE). Can be connected to the ground of the load.
4	TRIGGER Socket: Trigger input and "Charge Complete" optocoupler output.	9	Polarity indications: RED: POSITIVE BLUE: NEGATIVE RED/BLUE: REVERSE POLARITY SWITCHING
5	Air outlet (depending on model).		

Chargin process

The power supplies are equipped with a “CONTINUOUS/TRIGGER” switch (14) and a 6-pin socket. In the “CONTINUOUS” position, charging happens continuously, in the “TRIGGER” position, charging takes place after release by an external signal on the 6-pin interface.

Trigger-signal

The triggering is floating via an optocoupler. This input is standardised and designed for a control voltage between +12V and +24V. The control power source polarity is positive to pin 5 and negative to pin 6.

End of charge

When the final charging voltage is reached, this is indicated by the “CV” LED (6) illuminating (voltage reached). It is also reported to the external controller via an optocoupler on the trigger connector. This signal is isolated and it is passed through a downstream transistor from the optocoupler. An open collector signal with 100Ω series resistor is available on pins 3 and 4. (The transistor conducts with approx. 50mA, pin 4 LOW = End of charge).

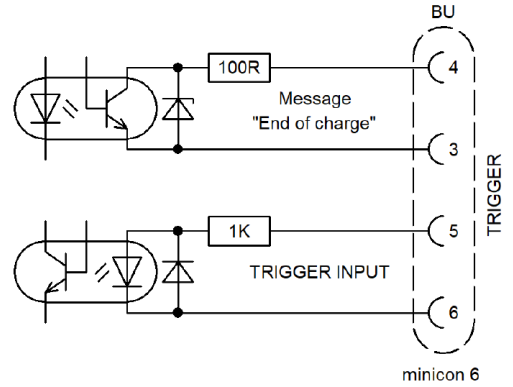

Number	Function	Number	Function
1/2	N/C	5/6	“Trigger” command
3/4	“CHARGE COMPLETE” message	5	ANODE
3	EMITTER	6	CATHODE GND
4	COLLECTOR		

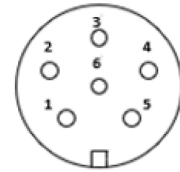

MINICON 6PIN
(Solder side of the plug)

Mechanical details

Model Number	Mounting	Width		Height		Depth	Weight ⁽²⁾
HCK2.0P400S	Bench mount ⁽¹⁾	19"	443mm	3U	133mm	350mm	11kg
HCK2.0N400S	Bench mount ⁽¹⁾	19"	443mm	3U	133mm	350mm	11kg
HCK2.0R400S	Bench mount ⁽¹⁾	19"	443mm	3U	133mm	350mm	11kg
HCK3.5P200S	Bench mount ⁽¹⁾	19"	443mm	3U	133mm	350mm	11kg
HCK3.5N400S	Bench mount ⁽¹⁾	19"	443mm	3U	133mm	350mm	11kg
HCK3.5R200S	Bench mount ⁽¹⁾	19"	443mm	3U	133mm	350mm	11kg
HCK6.5P120S	Bench mount ⁽¹⁾	19"	443mm	3U	133mm	350mm	11kg
HCK6.5N120S	Bench mount ⁽¹⁾	19"	443mm	3U	133mm	350mm	11kg
HCK6.5R120S	Bench mount ⁽¹⁾	19"	443mm	3U	133mm	350mm	11kg
HCK012P060S	Bench mount ⁽¹⁾	19"	443mm	3U	133mm	550mm	15kg
HCK012N060S	Bench mount ⁽¹⁾	19"	443mm	3U	133mm	550mm	15kg
HCK012R060S	Bench mount ⁽¹⁾	19"	443mm	3U	133mm	550mm	15kg
HCK020P040S	Bench mount ⁽¹⁾	19"	443mm	3U	133mm	550mm	15kg
HCK020N040S	Bench mount ⁽¹⁾	19"	443mm	3U	133mm	550mm	15kg
HCK020R040S	Bench mount ⁽¹⁾	19"	443mm	3U	133mm	550mm	15kg
HCK035P020S	Bench mount ⁽¹⁾	19"	443mm	3U	133mm	550mm	30kg
HCK035N020S	Bench mount ⁽¹⁾	19"	443mm	3U	133mm	550mm	30kg
HCK035R020S	Bench mount ⁽¹⁾	19"	443mm	3U	133mm	550mm	30kg
HCK065P012S	Bench mount ⁽¹⁾	19"	443mm	7U	310mm	550mm	55kg
HCK065N012S	Bench mount ⁽¹⁾	19"	443mm	7U	310mm	550mm	55kg
HCK065R012S	Bench mount ⁽¹⁾	19"	443mm	9U	399mm	550mm	70kg

Notes:

1. Rack mount options available, click on the link below for full details.
2. All weights are approximate.

Rack mount options

[→ view options](#)