

## 2.5kJ/s BENCH MOUNT

### AC-HVDC CAPACITOR CHARGERS

The HCK2K5 series are highly-stable DC power supplies, designed specially to meet the requirements of capacitor charging and capacitor conditioning. They feature a robust output resistor to be able to withstand the demands of a pulsed load. The control circuit is designed for fast transitions from constant current to constant voltage operation.

The equipment is suitable for both continuous and pulsed charging, this is achieved using an adjustable constant current without overshoot. Capacitors with a resistive component are also suitable as loads. Usually, an external protective resistor is not required. It is, however, recommended for applications with very high levels of stored energy.

The specified maximum charging power is achieved when charging from zero volt (0) to the rated voltage. The HCK series can operate in circuits where the load capacitor is fully discharged with each pulse, or in circuits where the load capacitor is only partially discharged with each pulse. The charging process can either be continuous or triggered using the external trigger input.



### Dimensions

See mechanical details table

### Features

- Output voltages 0-2kVDC to 0-65kVDC
- Three phase AC input
- Continuous operation at full rated power
- Multi-function control panel with user friendly interface
- Digital, LAN and USB interface option
- Analog programming/interface option
- Manual voltage and current control with digital display
- Set-point display via push-button
- Set-point adjustment possible with disabled output
- Push-button switch for output voltage
- Adjustable overvoltage limit
- CE marked, EN61010-1 safety compliant
- Short circuit & arc protection
- 2 year warranty

### Benefits

- Provides maximum device control & flexibility.
- Safe operation ensures maximum protection to the power supply
- High voltage release included for safe operation at high voltage output
- User friendly controls combined with bespoke terminal software gives greater flexibility
- Lighter than the leading brand products & easier to maintain
- Low cost of ownership

### Applications

- Capacitor charging
- Capacitor conditioning

## Models & Ratings

Model Number	Polarity	Output Voltage	Charge Power	Output Current	Input Voltage	Frequency
HCK2K5-2000P	Positive	0 to +2kV	2.5kJ/s	0 to 2.5A	400VAC ±10% 3 phase	47 to 63Hz
HCK2K5-2000N	Negative	0 to -2kV				47 to 63Hz
HCK2K5-3500P	Positive	0 to +3.5kV	2.5kJ/s	0 to 1.4A	400VAC ±10% 3 phase	47 to 63Hz
HCK2K5-3500N	Negative	0 to -3.5kV				47 to 63Hz
HCK2K5-6500P	Positive	0 to +6.5kV	2.5kJ/s	0 to 750mA	400VAC ±10% 3 phase	47 to 63Hz
HCK2K5-6500N	Negative	0 to -6.5kV				47 to 63Hz
HCK2K5-12500P	Positive	0 to +12.5kV	2.5kJ/s	0 to 400mA	400VAC ±10% 3 phase	47 to 63Hz
HCK2K5-12500N	Negative	0 to -12.5kV				47 to 63Hz
HCK2K5-20000P	Positive	0 to +20kV	2.5kJ/s	0 to 250mA	400VAC ±10% 3 phase	47 to 63Hz
HCK2K5-20000N	Negative	0 to -20kV				47 to 63Hz
HCK2K5-35000P	Positive	0 to +35kV	2.5kJ/s	0 to 140mA	400VAC ±10% 3 phase	47 to 63Hz
HCK2K5-35000N	Negative	0 to -35kV				47 to 63Hz
HCK2K5-65000P	Positive	0 to +65kV	2.5kJ/s	0 to 75mA	400VAC ±10% 3 phase	47 to 63Hz
HCK2K5-65000N	Negative	0 to -65kV				47 to 63Hz

## Options

- Analog programming
- Analog programming, floating
- Computer Interfaces – IEEE 488, RS 232, RS 422, RS485, Profibus DP, LAN, USB (more on request)
- Interlock
- Message output voltage <50V
- Higher stability: Stability, over 8 hours under constant conditions  $< \pm 1 \times 10^{-5}$   
Temperature coefficient  $< \pm 1 \times 10^{-5}/K$  within the specified temperature range
- Higher repetition frequency
- Heavy duty castors for rack unit
- Supply voltages other than that shown in the models & ratings table may be specified

Please consult XP Power Sales

## Input

Characteristic	Minimum	Typical	Maximum	Units	Notes & Conditions
Input Voltage					See models and ratings table
Efficiency		90		%	
Oversvoltage Category		II			
Protection Class		I			

## Output

Characteristic	Minimum	Typical	Maximum	Units	Notes & Conditions
Output Voltage Range	0		65	kV	See models and ratings table
Output Current Range	0		2.5	A	See models and ratings table
Output Control	Continuous adjustment from 0 to rated voltage/current by front panel mounted potentiometers				
Output Polarity	See models and ratings table				
Output Isolation	"0V" terminal is connected to the PE (EARTH), Current return preferably takes place via the screen of the output cable				
Stability		±0.1		%	Over 8 hours under constant conditions after 30 min. warm up
Voltage Setting Range	With the VOLTAGE ten-turn potentiometer, approx. 0,1% to 100% of the rated value (stable operation from 1%)				
Current Setting Range	With the CURRENT ten-turn potentiometer, approx. 0.1% to 100% of the rated value (stable operation from 1%)				
Set Point Resolution	$<\pm 1 \times 10^{-3}$ of rated value with potentiometer on front panel $<\pm 1 \times 10^{-5}$ of rated value with fine potentiometer $1 \times 10^{-4}$ of rated value with option interface				
Residual Ripple of Charging Current			10	%	pk-pk, of the rated value
Accuracy	Voltage: $<\pm 0.2\%$ of the nominal value Current: within the range of $>5\text{mA}$ up to $<200\text{A}$ : $\pm 0.2\%$ of the nominal value Outside the above mentioned range: $<\pm 0.5\%$ of the nominal value Additional digital display error $<\pm 2$ digits				
Charge Voltage Reproducibility	$\pm 10\%$ mains voltage variation: $<\pm 1 \times 10^{-4}$ of rated value Over 8h: $<\pm 1 \times 10^{-3}$ of rated value in temperature range of $<\pm 2 \times 10^{-4}/\text{K}$ At repetition frequency of $<10\text{Hz}$ : $<\pm 1 \times 10^{-3}$ of rated value At repetition frequency of $>10\text{Hz}$ : $<\pm 1 \times 10^{-2}$ of rated value				
Short Circuit Protection	The power supply is short-circuit and flash-over proof. The maximum current can be drawn at any output voltage even at short-circuit.				
Repetition Frequency			10	Hz	Optional up to 100Hz

## Safety Approvals

Safety Agency	Safety Standard	Notes & Conditions
EN	EN61010-1	
CE	Meets all applicable directives	
UKCA	Meets all applicable legislation	

## Environmental

Characteristic	Minimum	Typical	Maximum	Units	Notes & Conditions
Temperature Range	0		+40	°C	Operating and storage
Humidity	Max. relative humidity 80% up to +31°C, decreasing linearly down to 50% relative humidity at +40°C				Operating
	No precipitation and max. relative humidity of 80%				Storage
Cooling	Heat generated in the power supply unit is dissipated by convection or, in the case of high-power units > 400 J/s by forced cooling by ventilation.				
Operating Altitude		6,500 (2,000)		ft (m)	
Protection	Open/short circuits, arcs, overtemperature				

## Signals & Controls

	Function
Front panel	Voltage and current potentiometer, power switch, HV ON/OFF switch, display for current and voltage, voltage limit potentiometer. Display of the output voltage and current set points is possible with the VIEW SET push-button.  Feedback after reaching the end of charge voltage is provided using an LED on the front panel and via a voltage-isolated interface – "Trigger" BU2 (optocoupler output).
Capacitor charger operating modes	The capacitor charger can be operated without limits over the entire working range. Thus, the rated current can be continuously drawn at maximum voltage. If suitable interface options are present, you can choose between LOCAL, ANALOGUE and DIGITAL operating modes. The HV output's polarity is positive, negative; or reversible (see models & ratings table).

## EMC: Emissions

Phenomenon	Standard	Notes & Conditions
Harmonic Currents	EN61000-6-2	
Voltage Flicker	EN61000-6-3	

Mechanical Details

Front view with controls

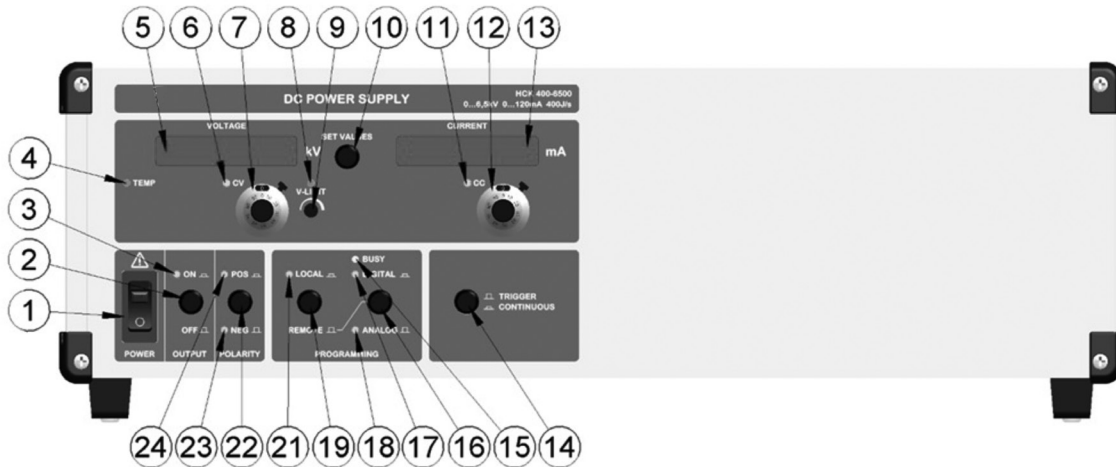

Front panel shown for illustrative purposes only, dimensions and layout differ by power rating - see mechanical details table.

Number	Function	Number	Function
1	AC power switch with indicator light Disconnects the power supply from the mains, double-pole switching	13	Current display flashing: Set point; not flashing: Actual value
2	HV Output ON/OFF button (There is no mains disconnection)	14	Charging Mode – continuous charging or via external trigger
3	HV ON LED Lights up green when the regulation and therefore the power stage is operating (OUTPUT ON)	15	BUSY LED displays data traffic on the digital interface (Optional)
4	Over-temperature LED, internal device temperature too high, fan failure or blocked (Use is type-dependent)	16	Switching the operation mode between REMOTE/ANALOG and REMOTE/DIGITAL (Optional)
5	Voltage display flashing: Set point; not flashing: Actual value	17	LED indicating digital programming active (Optional)
6	LED for constant voltage control mode (constant voltage)	18	LED indicating analog programming active (Optional)
7	Lockable ten-turn potentiometer for output voltage adjustment	19	Switching the operation mode between LOCAL and REMOTE, control mode (Optional)
8	Air inlet (depending on device type)	20	Unused
9	Set-point limit adjustment for voltage V-LIMIT (can be operated with a screwdriver)	21	LED indicating local control mode active (Optional)
10	Push button for SET VALUES switch displays between set point and actual output mode, displays flash when in set point mode	22	Polarity reversal: Local output polarity selection Without polarity reversal, labelling of polarity using coloured label: RED: POSITIVE; BLUE: NEGATIVE (Optional)
11	LED for constant current mode (constant current)	23	LED for negative output voltage set (Optional polarity reversal)
12	Lockable Ten-turn-potentiometer for output current adjustment	24	LED for positive output voltage set (Optional polarity reversal)

Mechanical Details

Rear view with three-phase AC input

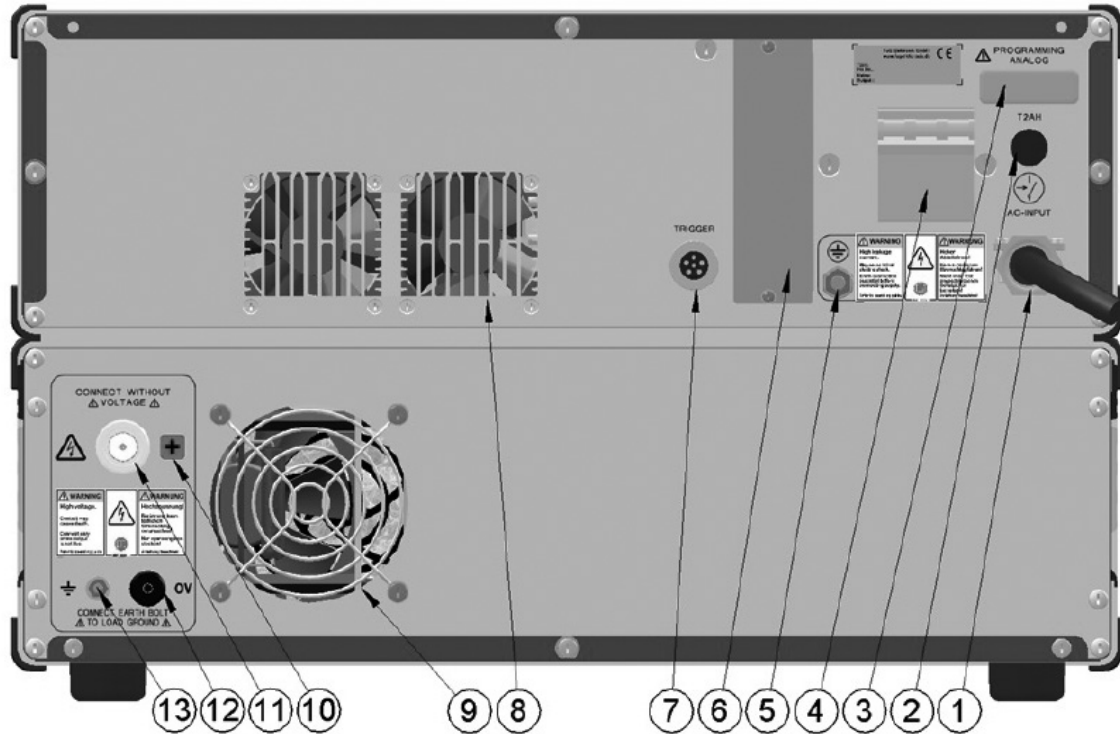

Rear panel shown for illustrative purposes only, dimensions and layout differ by power rating - see mechanical details table.

Number	Function	Number	Function
1	Mains input with fixed installed cable, for 3 phase mains	8	Air outlet for forced cooling (power output stage)
2	Fuse holder for internal electronics fuse	9	Air outlet
3	15 pin Sub-D connector for analog programming (Optional)	10	Polarity indication RED: POSITIVE BLUE: NEGATIV RED/BLUE: OPTION UMPOLUNG POLARITY REVERSAL
4	Automatic circuit breaker, fuse holder	11	HV – Output
5	Earthing bolt (only for power supplies with 3 phase mains input). These power supplies have to be properly connected to earth via this earthing bolt with 10mm <sup>2</sup>	12	0V terminal, internally connected to 0V of electronics. The 0V terminal is connected to housing of power supply, to the shielding of the output cable and to PE (earth).
6	Option port for digital interface (e.g., IEEE 488, RS232, USB, LAN)	13	Earthing bolt: This terminal must be connected to the earth of the load
7	Trigger-socket (Trigger input and “Charge complete” optocoupler output)		

## Charging Process

The power supplies are equipped with a “CONTINUOUS/TRIGGER” switch (14) and a 6-pin socket. In the “CONTINUOUS” position, charging happens continuously, in the “TRIGGER” position, charging takes place after release by an external signal on the 6-pin interface.

### Trigger-Signal

The triggering is floating via an optocoupler. This input is standardised and designed for a control voltage between +12V and +24V. The control power source polarity is positive to pin 5 and negative to pin 6.

### End of charge

When the final charging voltage is reached, this is indicated by the “CV” LED (6) illuminating (voltage reached). It is also reported to the external controller via an optocoupler on the trigger connector. This signal is isolated and it is passed through a downstream transistor from the optocoupler. An open collector signal with 100Ω series resistor is available on pins 3 and 4. (The transistor conducts with approx. 50mA, pin 4 LOW = End of charge).

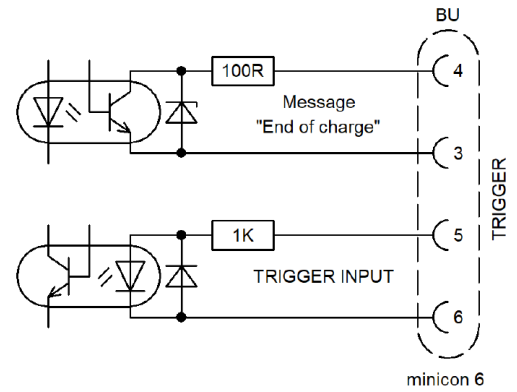

Number	Function	Number	Function
1/2	N/C	5/6	“Trigger” command
3/4	“CHARGE COMPLETE” message	5	ANODE
3	EMITTER	6	CATHODE GND
4	COLLECTOR		

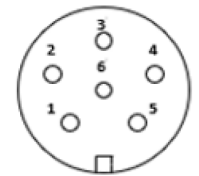

**MINICON 6 pin**  
(solder side of plug)

## Mechanical Details

Model Number	Mounting	Width		Height		Depth	Weight
HCK2K5-2000P	Bench mount <sup>(1)</sup>	19"	443mm	6U	266mm	650mm	30kg
HCK2K5-2000N	Bench mount <sup>(1)</sup>	19"	443mm	6U	266mm	650mm	30kg
HCK2K5-3500P	Bench mount <sup>(1)</sup>	19"	443mm	9U	399mm	650mm	40kg
HCK2K5-3500N	Bench mount <sup>(1)</sup>	19"	443mm	9U	399mm	650mm	40kg
HCK2K5-6500P	Bench mount <sup>(1)</sup>	19"	443mm	6U	266mm	650mm	40kg
HCK2K5-6500N	Bench mount <sup>(1)</sup>	19"	443mm	6U	266mm	650mm	40kg
HCK2K5-12500P	Bench mount <sup>(1)</sup>	19"	443mm	6U	266mm	650mm	40kg
HCK2K5-12500N	Bench mount <sup>(1)</sup>	19"	443mm	6U	266mm	650mm	40kg
HCK2K5-20000P	Bench mount <sup>(1)</sup>	19"	443mm	6U	266mm	650mm	40kg
HCK2K5-20000N	Bench mount <sup>(1)</sup>	19"	443mm	6U	266mm	650mm	40kg
HCK2K5-35000P	Bench mount <sup>(1)</sup>	19"	443mm	6U	266mm	650mm	50kg
HCK2K5-35000N	Bench mount <sup>(1)</sup>	19"	443mm	6U	266mm	650mm	50kg
HCK2K5-65000P	Mini rack	19"	553mm	12U	535mm	800mm	120kg
HCK2K5-65000N	Mini rack	19"	553mm	12U	535mm	800mm	120kg

### Notes:

1. Rack mount option

### Cables

#### Mains input cable

3 phase mains: open end

#### Mating connectors

For control inputs and outputs not included (digital interface cables are commercially available).

#### Screened HV output cable

3m long with mating connector fitted one end only. Delivered short circuited for safety reasons.