

10kJ/s FULL RACK

AC-HVDC CAPACITOR CHARGERS

The HCK10K0 series are highly-stable DC power supplies, designed specially to meet the requirements of capacitor charging and capacitor conditioning. They feature a robust output resistor to be able to withstand the demands of a pulsed load. The control circuit is designed for fast transitions from constant current to constant voltage operation.

The equipment is suitable for both continuous and pulsed charging, this is achieved using an adjustable constant current without overshoot. Capacitors with a resistive component are also suitable as loads. Usually, an external protective resistor is not required. It is, however, recommended for applications with very high levels of stored energy.

The specified maximum charging power is achieved when charging from zero volt (0) to the rated voltage. The HCK series can operate in circuits where the load capacitor is fully discharged with each pulse, or in circuits where the load capacitor is only partially discharged with each pulse. The charging process can either be continuous or triggered using the external trigger input.



Dimensions

See mechanical details table

Features

- Output voltages 0-2kVDC to 0-65kVDC
- Three phase AC input
- Continuous operation at full rated power
- Multi-function control panel with user friendly interface
- Digital, LAN and USB interface option
- Analog programming/interface option
- Manual voltage and current control with digital display
- Set-point display via push-button
- Set-point adjustment possible with disabled output
- Push-button switch for output voltage
- Adjustable overvoltage limit
- CE marked, EN61010-1 safety compliant
- Short circuit & arc protection
- 2 year warranty

Benefits

- Provides maximum device control & flexibility.
- Safe operation ensures maximum protection to the power supply
- High voltage release included for safe operation at high voltage output
- User friendly controls combined with bespoke terminal software gives greater flexibility
- Lighter than the leading brand products & easier to maintain
- Low cost of ownership

Applications

- Capacitor charging
- Capacitor conditioning

Models & Ratings

Model Number	Polarity	Output Voltage	Charge Power	Output Current	Input Voltage	Frequency
HCK10K0-2000P	Positive	0 to +2kV	10kJ/s	0 to 10A	400VAC, ±10% 3 phase	47 to 63Hz
HCK10K0-2000N	Negative	0 to -2kV				
HCK10K0-3500P	Positive	0 to +3.5kV	10kJ/s	0 to 5.7A	400VAC, ±10% 3 phase	47 to 63Hz
HCK10K0-3500N	Negative	0 to -3.5kV				
HCK10K0-6500P	Positive	0 to +6.5kV	10kJ/s	0 to 3A	400VAC, ±10% 3 phase	47 to 63Hz
HCK10K0-6500N	Negative	0 to -6.5kV				
HCK10K0-12500P	Positive	0 to +12.5kV	10kJ/s	0 to 1.5A	400VAC, ±10% 3 phase	47 to 63Hz
HCK10K0-12500N	Negative	0 to -12.5kV				
HCK10K0-20000P	Positive	0 to +20kV	10kJ/s	0 to 1A	400VAC, ±10% 3 phase	47 to 63Hz
HCK10K0-20000N	Negative	0 to -20kV				
HCK10K0-35000P	Positive	0 to +35kV	10kJ/s	0 to 570mA	400VAC, ±10% 3 phase	47 to 63Hz
HCK10K0-35000N	Negative	0 to -35kV				
HCK10K0-65000P	Positive	0 to +65kV	10kJ/s	0 to 300mA	400VAC, ±10% 3 phase	47 to 63Hz
HCK10K0-65000N	Negative	0 to -65kV				

Options

- Analog programming
- Analog programming, floating
- Computer Interfaces - IEEE 488, RS 232, RS 422, RS485, Profibus DP, LAN, USB (more on request)
- Interlock
- Message output voltage <50V
- Higher stability: Stability, over 8 hours under constant conditions $<\pm 1 \times 10^{-5}$
Temperature coefficient $<\pm 1 \times 10^{-5}/K$ within the specified temperature range
- Higher repetition frequency
- Heavy duty castors for rack unit
- Supply voltages other than that shown in the models & ratings table may be specified

Please consult XP Power Sales

Input

Characteristic	Minimum	Typical	Maximum	Units	Notes & Conditions
Input Voltage					See models and ratings table
Efficiency		90		%	
Oversvoltage Category		II			
Protection Class		I			

Output

Characteristic	Minimum	Typical	Maximum	Units	Notes & Conditions
Output Voltage Range	0		65	kV	See models and ratings table
Output Current Range	0		10	A	See models and ratings table
Output Control	Continuous adjustment from 0 to rated voltage/current by front panel mounted potentiometers				
Output Polarity	See models and ratings table				
Output Isolation	"0V" terminal is connected to the PE (EARTH), Current return preferably takes place via the screen of the output cable				
Stability		±0.1		%	Over 8 hours under constant conditions after 30 min. warm up
Voltage Setting Range	With the VOLTAGE ten-turn potentiometer, approx. 0,1% to 100% of the rated value (stable operation from 1%)				
Current Setting Range	With the CURRENT ten-turn potentiometer, approx. 0.1% to 100% of the rated value (stable operation from 1%)				
Set Point Resolution	$<\pm 1 \times 10^{-3}$ of rated value with potentiometer on front panel $<\pm 1 \times 10^{-5}$ of rated value with fine potentiometer 1×10^{-4} of rated value with option interface				
Residual Ripple of Charging Current			10	%	pk-pk, of the rated value
Accuracy	Voltage: $<\pm 0.2\%$ of the nominal value Current: within the range of $>5\text{mA}$ up to $<200\text{A}$: $\pm 0.2\%$ of the nominal value Outside the above mentioned range: $<\pm 0.5\%$ of the nominal value Additional digital display error $<\pm 2$ digits				
Charge Voltage Reproducibility	$\pm 10\%$ mains voltage variation: $<\pm 1 \times 10^{-4}$ of rated value Over 8h: $<\pm 1 \times 10^{-3}$ of rated value in temperature range of $<\pm 2 \times 10^{-4}/\text{K}$ At repetition frequency of $<10\text{Hz}$: $<\pm 1 \times 10^{-3}$ of rated value At repetition frequency of $>10\text{Hz}$: $<\pm 1 \times 10^{-2}$ of rated value				
Short Circuit Protection	The power supply is short-circuit and flash-over proof. The maximum current can be drawn at any output voltage even at short-circuit.				
Repetition Frequency			10	Hz	Optional up to 100Hz

Safety Approvals

Safety Agency	Safety Standard	Notes & Conditions
EN	EN61010-1	
CE	Meets all applicable directives	
UKCA	Meets all applicable legislation	

Environmental

Characteristic	Minimum	Typical	Maximum	Units	Notes & Conditions
Temperature Range	0		+40	°C	Operating and storage
Humidity	Max. relative humidity 80% up to +31°C, decreasing linearly down to 50% relative humidity at +40°C				Operating
	No precipitation and max. relative humidity of 80%				Storage
Cooling	Heat generated in the power supply unit is dissipated by convection or, in the case of high-power units >400J/s by forced cooling by ventilation.				
Operating Altitude		6,500 (2,000)		ft (m)	
Protection	Open/short circuits, arcs, overtemperature				

Signals & Controls

	Function
Front panel	<p>Voltage and current potentiometer, power switch, HV ON/OFF switch, display for current and voltage, voltage limit potentiometer. Display of the output voltage and current set points is possible with the VIEW SET push-button.</p> <p>Feedback after reaching the end of charge voltage is provided using an LED on the front panel and via a voltage-isolated interface – “Trigger” BU2 (optocoupler output).</p>
Capacitor charger operating modes	<p>The capacitor charger can be operated without limits over the entire working range. Thus, the rated current can be continuously drawn at maximum voltage. If suitable interface options are present, you can choose between LOCAL, ANALOGUE and DIGITAL operating modes. The HV output’s polarity is positive, negative; or reversible (see models & ratings table).</p>

EMC: Emissions

Phenomenon	Standard	Notes & Conditions
Harmonic Currents	EN61000-6-2	
Voltage Flicker	EN61000-6-3	

Mechanical Details

View of cabinet unit (typical example)

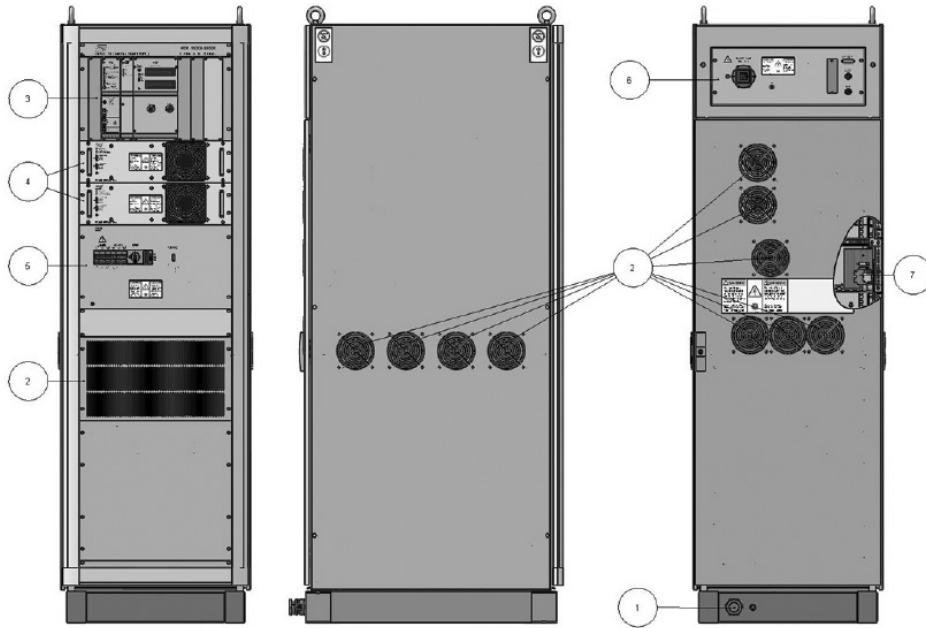

Number	Function	Number	Function
1	AC input	5	Mains control
2	Air outlet	6	HV output
3	Electronics	7	Mains connection
4	Power-driver		

Cabinet unit shown for illustrative purposes only, dimensions and layout differ by power rating - see mechanical details table.

Cabinet unit: Front view with front panel and AC input (typical example)

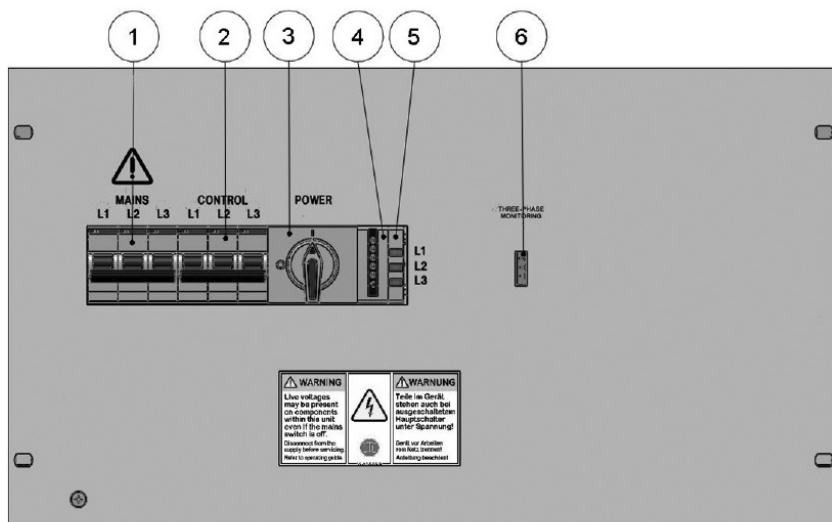

Number	Function
1	Main and automatic circuit breaker, disconnection from the mains
2	Automatic circuit breaker for electronics, no disconnection from the mains
3	Main switch
4	Elapsed hour counter
5	Status LED L1, L2 and L3 (phase display)
6	Phase and mains monitoring relay

Front view shown for illustrative purposes only, dimensions and layout differ by power rating - see mechanical details table.

Mechanical Details

Cabinet unit: Front panel and electronics (typical example)

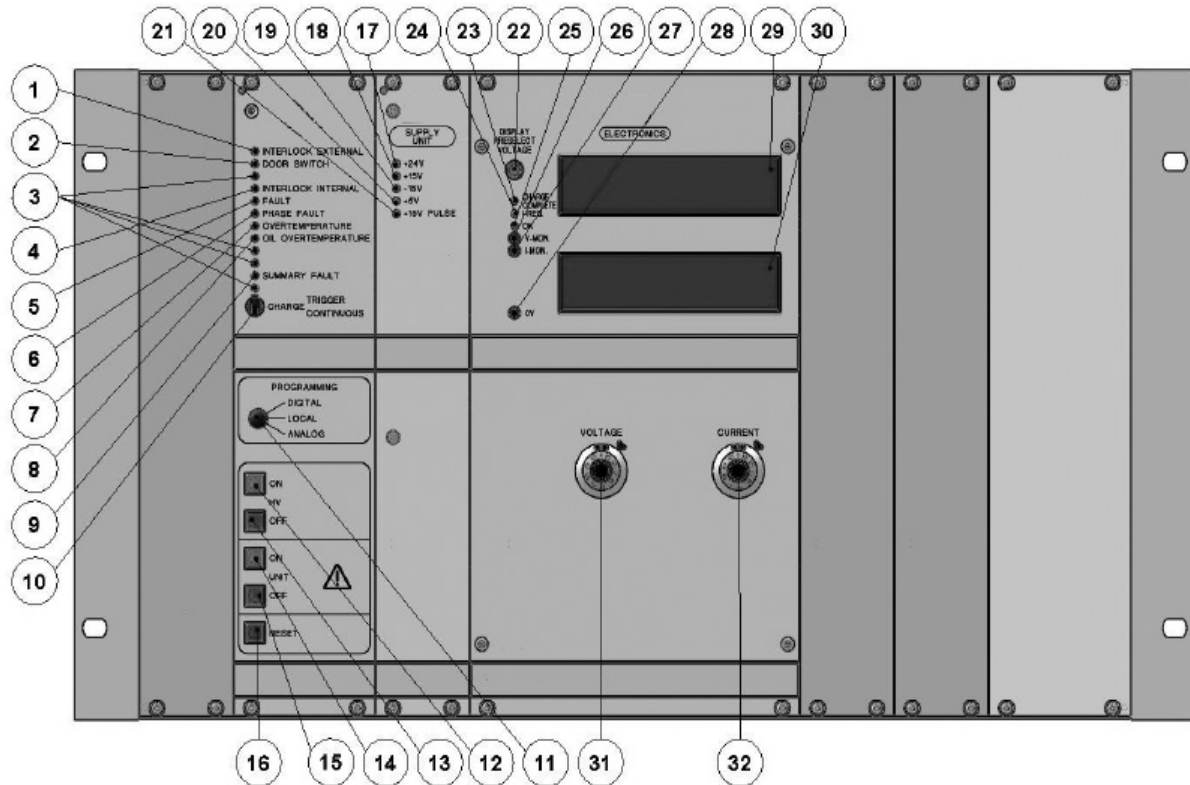

Front view shown for illustrative purposes only, dimensions and layout differ by power rating - see mechanical details table.

Number	Function	Number	Function
1	LED external interlock loop open	17	LED +24V supply OK
2	LED door open	18	LED +15V supply OK
3	Unused, free available for special features, e.g., smoke alarm, signal of interface	19	LED -15V supply OK
4	LED internal interlock loop open	20	LED +5V supply OK
5	LED internal error	21	LED +15V pulsed power supply OK
6	LED phase error	22	Switch to display of set values/measured values (voltage)
7	LED unit overtemperature	23	LED charging voltage reached "CHARGE COMPLETE" (constant voltage mode)
8	LED oil overtemperature	24	LED current control activated "I-REG"
9	LED summary fault	25	LED status OK
10	Charging mode: external Trigger - continuous	26	Socket for voltage monitoring (0-10V)
11	Programming (optional): digital – local – analog	27	Socket for current monitoring (0-10V)
12	HV on	28	Reference socket "0V"
13	HV off	29	Voltage display (kV)
14	Mains connection on	30	Current display (mA)
15	Mains connection off	31	Fixable ten-turn potentiometer for voltage setpoint
16	Resetting the error memory	32	Fixable ten-turn potentiometer for current set point

Mechanical Details

Cabinet unit: Power driver (typical example)



Power driver shown for illustrative purposes only, dimensions and layout differ by power rating - see mechanical details table.

Number	Function	Number	Function
1	LED internal fuse defective	8	LED overcurrent part B
2	LED asymmetrical voltage at the output stage	9	Socket (internal resistance 10kΩ) for monitoring the primary current of the transformer 10A/0.2V
3	LED driver overtemperature	10	Socket for monitoring the PWM signal (PULSE 1B)
4/9	LED overcurrent part A	11	Socket for monitoring the PWM signal (PULSE 2B)
5	Socket (internal resistance 10kΩ) for monitoring the primary current of the transformer 10A/0.2V	12	Reference socket "0V"
6	Socket for monitoring the PWM signal (PULSE 1A)	13	Cooling fan
7	Socket for monitoring the PWM signal (PULSE 2A)		

Charging Process

The power supplies are equipped with a "CONTINUOUS/TRIGGER" switch (14) and a 6-pin socket. In the "CONTINUOUS" position, charging happens continuously, in the "TRIGGER" position, charging takes place after release by an external signal on the 6-pin interface.

Trigger-Signal

The triggering is floating via an optocoupler. This input is standardised and designed for a control voltage between +12V and +24V. The control power source polarity is positive to pin 5 and negative to pin 6.

End of charge

When the final charging voltage is reached, this is indicated by the "CV" LED (6) illuminating (voltage reached). It is also reported to the external controller via an optocoupler on the trigger connector. This signal is isolated and it is passed through a downstream transistor from the optocoupler. An open collector signal with 100Ω series resistor is available on pins 3 and 4. (The transistor conducts with approx. 50mA, pin 4 LOW = End of charge).

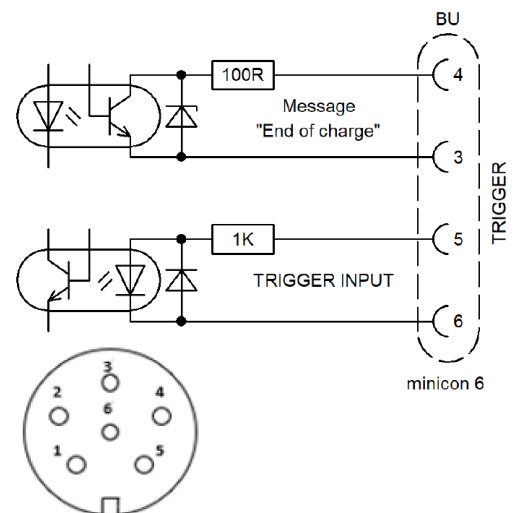

Number	Function	Number	Function
1/2	N/C	5/6	"Trigger" command
3/4	"CHARGE COMPLETE" message	5	ANODE
3	EMITTER	6	CATHODE GND
4	COLLECTOR		

MINICON 6 pin (solder side of plug)

Mechanical Details

Model Number	Mounting	Width		Height		Depth	Weight
HCK10K0-2000P	Full rack	19"	600mm	42U	2200mm	800mm	240kg
HCK10K0-2000N	Full rack	19"	600mm	42U	2200mm	800mm	240kg
HCK10K0-3500P	Full rack	19"	600mm	42U	2200mm	800mm	240kg
HCK10K0-3500N	Full rack	19"	600mm	42U	2200mm	800mm	240kg
HCK10K0-6500P	Full rack	19"	600mm	42U	2200mm	800mm	240kg
HCK10K0-6500N	Full rack	19"	600mm	42U	2200mm	800mm	240kg
HCK10K0-12500P	Full rack	19"	600mm	42U	2200mm	800mm	240kg
HCK10K0-12500N	Full rack	19"	600mm	42U	2200mm	800mm	240kg
HCK10K0-20000P	Full rack	19"	600mm	42U	2200mm	800mm	240kg
HCK10K0-20000N	Full rack	19"	600mm	42U	2200mm	800mm	240kg
HCK10K0-35000P	Full rack	19"	600mm	42U	2200mm	800mm	450kg
HCK10K0-35000N	Full rack	19"	600mm	42U	2200mm	800mm	450kg
HCK10K0-65000P	Full rack	19"	600mm	42U	2200mm	800mm	500kg
HCK10K0-65000N	Full rack	19"	600mm	42U	2200mm	800mm	500kg

Cables

Mains input cable

3 phase mains: open end

Mating connectors

For control inputs and outputs not included (digital interface cables are commercially available).

Screened HV output cable

3m long with mating connector fitted one end only. Delivered short circuited for safety reasons.