

110 Watts

- Complete AC/DC Power Supply
- No Extra Components Required
- Base Plate Cooled
- -40 to +85 °C Base Plate Temperature
- Low Profile in Full Brick Package
- High Efficiency - Up to 91%
- Universal Input
- <0.3 W No Load Input Power
- Optional Heatsink Available
- Over Current, Over Voltage and Over Temperature Protection
- 3 Year Warranty



Dimensions:

ASB110:
4.6 x 2.4 x 0.67" (116.8 x 61 x 17 mm)

The ASB110 series is a range of complete low profile, full brick, base-plate cooled AC-DC power supplies which require no external components. The series includes a complete built in EMC filter and AC Fuse as well as bulk storage capacitor providing a complete AC-DC power solution ready for installation into end applications. The ASB110 offers high efficiency to minimise waste heat and heat sinking requirements and operates from -40 °C to +85 °C on the module base-plate.

Models & Ratings

Output Power	Output Voltage	Output Current	Noise and Ripple	Efficiency ⁽¹⁾	Model Number ⁽²⁾
110 W	12.0V	9.17 A	120 mV	90.0%	ASB110PS12
	15.0V	7.33 A	150 mV	90.0%	ASB110PS15
	24.0V	4.58 A	240 mV	91.0%	ASB110PS24
	28.0V	3.93 A	280 mV	91.0%	ASB110PS28
	36.0V	3.06 A	360 mV	91.0%	ASB110PS36
	48.0V	2.29 A	480 mV	90.5%	ASB110PS48

Notes

1. Typical efficiency with 230 VAC input and full load.
2. Add suffix '-HK-' to receive with optional heat-sink fitted.

Input

Characteristic	Minimum	Typical	Maximum	Units	Notes & Conditions
Input Voltage	85		264	VAC	Derate linearly from 100% load at 90 VAC to 90% load at 85 VAC
Input Frequency	47		63	Hz	
Input Current		1.1/0.6		A	115 VAC/Measured at 230 VAC
Inrush Current			70	A	230 VAC, cold start at 25 °C
Power Factor		>0.9			Full load
Earth Leakage Current			500	µA	264 VAC, 60 Hz
No Load Input Power			0.3	W	
Input Protection	Internal T3.15A/250 VAC fitted in line				

General

Characteristic	Minimum	Typical	Maximum	Units	Notes & Conditions
Efficiency		90		%	See Models and Ratings table
Isolation: Input to Output Input to Ground Output to Ground			3000	VAC	
			1500	VAC	
			500	VDC	
Switching Frequency		70-130 / 50-90		kHz	PFC / PWM
Power Density		14.8		W/in ³	
Mean Time Between Failure	160			kHrs	MIL-HDBK-217F at 25 °C GB
Weight		0.51 (230)		lb (g)	

Output

Characteristic	Min.	Typ.	Max.	Units	Notes & Conditions
Output Voltage	12		48	VDC	See Models and Ratings table
Initial Set Accuracy		1		%	At 60% load
Minimum Load					No minimum load required
Start Up Delay			1.3	s	
Start Up Rise Time			20	ms	
Hold Up Time	10			ms	Full load and 115 VAC
Line Regulation			±0.5	%	
Load Regulation			±0.5	%	
Transient Response			2	%	Maximum deviation, recovering to less than 1% within 300 µs for 25% step load
Ripple and Noise			1	% pk-pk	20 MHz bandwidth, measured with 20 MHz Bandwidth and 10 µF electrolytic in parallel with 0.1 µF ceramic capacitor.
Overload Protection	130		210	%	
Overvoltage Protection	110		140	%	Recycle mains to reset
Short Circuit Protection	Trip and restart (hiccup), auto resetting				
Thermal Protection	Measured internally, auto resetting				
Temperature Coefficient		0.02		%/°C	

Environmental

Characteristic	Minimum	Typical	Maximum	Units	Notes & Conditions
Operating Temperature	-40		+85	°C	Baseplate Temperature, see derating curve
Cooling	Conduction Cooled via Baseplate				
Operating Humidity	5		90	%RH	Non-condensing
Storage Temperature	-40		+85	°C	
Operating Altitude			3048	m	
Shock	IEC68-2-27, 30 g, 11 ms half sine, 3 times in each of 6 axes				
Vibration	IEC68-2-6, 10-500 Hz, 2 g 10 mins/sweep, 60 mins for each of 3 axes				

EMC: Emissions

Phenomenon	Standard	Test Level	Notes & Conditions
Emissions	EN55032	Level B	
Harmonic Current	EN61000-3-2	Class A	
Voltage Flicker	EN61000-3-3		

EMC: Immunity

Phenomenon	Standard	Test Level	Criteria	Notes & Conditions
ESD	EN61000-4-2	3/2	A	±8 kV air/±4 kV contact
Radiated	EN61000-4-3	3 V/m	A	
EFT/Burst	EN61000-4-4	3	A	
Surge	EN61000-4-5	Installation Class 3	A	
Conducted	EN61000-4-6	3 V	A	
Dips and Interruptions	EN61000-4-11	Dip: 100% 10 ms	A	
		Dip: 30% 500 ms	A/B	High Line/Low Line
		Int:100% 5000 ms	B	

Safety Approvals

Safety Agency	Safety Standard	Notes & Conditions
UL	UL60950-1	
TUV	EN60950-1	
CB	IEC60950-1	

Mechanical Details



Optional Heatsink (IFH HEATSINK)

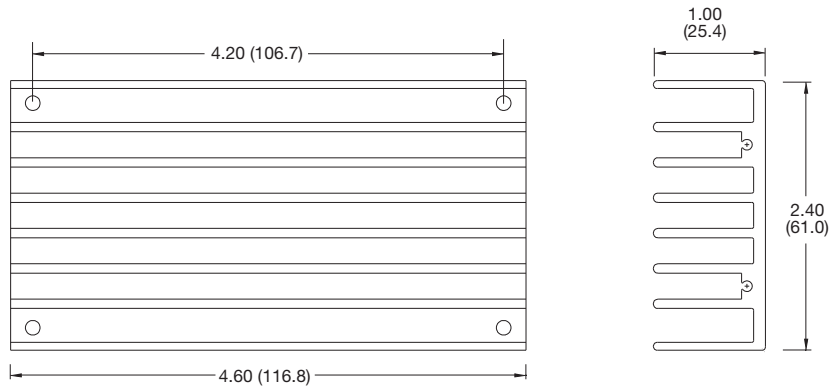

Notes

1. Dimensions shown in inches (mm).
2. Weight: 0.51 lb (230 g)
3. Pin diameter: 0.08 ± 0.002 (2.0 ± 0.05)
4. Pin pitch tolerance: ± 0.014 (± 0.35)
5. Case tolerance: ± 0.02 (± 0.5)
6. Baseplate is connected to FG Pin

Application Notes

Derating Curve



Notes

When ASB110 is fitted with IFH HEATSINK and mounted in horizontal position with heatsink upper most, the base plate temperature will typically be 85 °C in an ambient of 50 °C.

Application Notes

Efficiency Curves

ASB110PS12



ASB110PS24

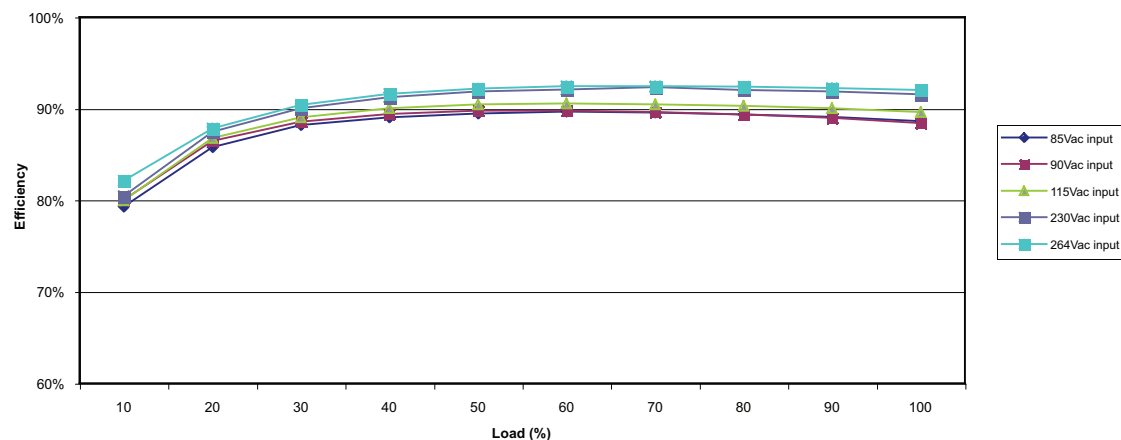

Lifetime

