

# 400-2500 Watts flexPower Series



- Configurable for Fast Time to Market
- SEMI F47 Compliant
- Flexible Series & Parallel Capability
- -20 °C Operation
- Extra Power Available at High Line
- Optional Fan Speed Control
- 3 Year Warranty

## Specification

### Input

Input Voltage	<ul style="list-style-type: none"> <li>• 85-264 VAC (120-370 VDC). Full power at 90 VAC, derate by 10% at 85 VAC</li> </ul>
Input Frequency	<ul style="list-style-type: none"> <li>• 47-63 Hz, 400 Hz (all specifications met at 400 Hz, except leakage current)</li> </ul>
Input Current <sup>(1)</sup>	<ul style="list-style-type: none"> <li>• X4: 5.33 A at 115 VAC, 2.67 A at 230 VAC</li> <li>• X5: 6.67 A at 115 VAC, 3.33 A at 230 VAC</li> <li>• X7: 9.33 A at 115 VAC, 4.67 A at 230 VAC</li> <li>• X9: 12.0 A at 115 VAC, 6.00 A at 230 VAC</li> <li>• X10: 13.3 A at 115 VAC, 6.67 A at 230 VAC</li> <li>• X15: 20 A at 115 VAC, 10 A at 230 VAC</li> </ul>
Inrush Current <sup>(1)</sup>	<ul style="list-style-type: none"> <li>• X4, X5, X7: &lt;20 A, X9/X10: &lt;40 A, X15: &lt;60 A, cold start at 25 °C</li> </ul>
Power Factor	<ul style="list-style-type: none"> <li>• 0.99 typical at 115 VAC &amp; 230 VAC full load</li> </ul>
Earth Leakage Current <sup>(1)</sup>	<ul style="list-style-type: none"> <li>• X models &lt;1.5 mA at 264 VAC, 50 Hz</li> <li>• XM models &lt;200 µA at 264 VAC, 50 Hz</li> </ul>
Input Protection	<ul style="list-style-type: none"> <li>• X4-7/XM4-7: T12 A/250 V, X9/XM9: T15 A/250 V, X10/XM10: T20 A/250 V, X15/XM15: T20 A/250 V, internal fuse in line and neutral</li> </ul>

### Output

Output Power	<ul style="list-style-type: none"> <li>• See table</li> </ul>
Output Voltage	<ul style="list-style-type: none"> <li>• See table</li> </ul>
Output Voltage Trim	<ul style="list-style-type: none"> <li>• 3.3 V outputs ±6%, others ±10%</li> </ul>
Minimum Load	<ul style="list-style-type: none"> <li>• No min load required for 2 slot or 3 slot single output modules. 2 slot dual outputs require 10% load on V1 to meet specified regulation on V2</li> </ul>
Start Up Delay	<ul style="list-style-type: none"> <li>• 2 s typical</li> </ul>
Hold Up Time	<ul style="list-style-type: none"> <li>• 20 ms at 90 VAC input &amp; full output load</li> </ul>
Line Regulation	<ul style="list-style-type: none"> <li>• &lt;0.1%</li> </ul>
Load Regulation	<ul style="list-style-type: none"> <li>• &lt;1.0%</li> </ul>
Ripple & Noise	<ul style="list-style-type: none"> <li>• 50 mV or 1% pk-pk at 20 MHz bandwidth, whichever is greater</li> </ul>
Overvoltage Protection	<ul style="list-style-type: none"> <li>• 115-130% Vnom</li> </ul>
Overtemperature Protection	<ul style="list-style-type: none"> <li>• 115 °C measured internally, recycle mains to reset</li> </ul>
Overload Protection	<ul style="list-style-type: none"> <li>• 110-140%</li> </ul>
Short Circuit Protection	<ul style="list-style-type: none"> <li>• Continuous trip &amp; restart (hiccup mode)</li> </ul>
Temperature Coefficient	<ul style="list-style-type: none"> <li>• 0.03%/°C</li> </ul>
Remote Sense	<ul style="list-style-type: none"> <li>• Compensates for up to 0.5 V drop</li> </ul>
Enable/Inhibit	<ul style="list-style-type: none"> <li>• See signals page</li> </ul>
Current Share	<ul style="list-style-type: none"> <li>• See signals page</li> </ul>
Housekeeping Voltage	<ul style="list-style-type: none"> <li>• 5 V/1 A from each chassis</li> </ul>

### General

Efficiency	<ul style="list-style-type: none"> <li>• Up to 89%</li> </ul>
Isolation	<ul style="list-style-type: none"> <li>• 4000 VAC Input to Output 2 x MOPP, 1500 VAC Input to Ground 1 x MOPP, 250 VDC Output to Ground</li> </ul>
Switching Frequency	<ul style="list-style-type: none"> <li>• 60 kHz typ PFC, 200 kHz typ modules</li> </ul>
Signals	<ul style="list-style-type: none"> <li>• See signals page</li> </ul>
MTBF	<ul style="list-style-type: none"> <li>• 225 kHrs typ to MIL-HDBK-217F at 25 °C, GB</li> </ul>

### Environmental

Operating Temperature	<ul style="list-style-type: none"> <li>• -20 °C to +70 °C. For operation above +50 °C, derate linearly to 50% load at +70 °C. Reverse air option derate from +40 °C to half load at +60 °C</li> </ul>
Cooling	<ul style="list-style-type: none"> <li>• Forced air cooling (via field-replaceable internal fan). Fan speed control optional</li> </ul>
Operating Humidity	<ul style="list-style-type: none"> <li>• 5-95% RH, non-condensing</li> </ul>
Storage Temperature	<ul style="list-style-type: none"> <li>• -40 °C to +85 °C</li> </ul>
Operating Altitude	<ul style="list-style-type: none"> <li>• 3000 m at full specification</li> </ul>
Shock	<ul style="list-style-type: none"> <li>• MIL STD-810 Method 516.4 Procedure 1, 30 g, half sine, 6 axes</li> </ul>
Vibration	<ul style="list-style-type: none"> <li>• MIL STD-810 Method 514.4 Procedure 1, 1 g rms, 5-500 Hz, 3 axes</li> </ul>

### EMC & Safety

Emissions	<ul style="list-style-type: none"> <li>• X version: EN55022 (CISPR22) Class B conducted</li> <li>• XM version: EN55011 (CISPR 11) Class A conducted</li> </ul>
Immunity	<ul style="list-style-type: none"> <li>• EN60601-1-2, EN61204-3</li> </ul>
Harmonic Currents	<ul style="list-style-type: none"> <li>• EN61000-3-2, Class A</li> </ul>
Voltage Flicker	<ul style="list-style-type: none"> <li>• EN61000-3-3</li> </ul>
ESD Immunity	<ul style="list-style-type: none"> <li>• EN61000-4-2, level 4 Perf Criteria A</li> </ul>
Radiated Immunity	<ul style="list-style-type: none"> <li>• EN61000-4-3, 10 V/m Perf Criteria A</li> </ul>
EFT/Burst	<ul style="list-style-type: none"> <li>• EN61000-4-4, level 3 Perf Criteria A</li> </ul>
Surge	<ul style="list-style-type: none"> <li>• EN61000-4-5, installation class 3, Perf Criteria A, SEMI F47</li> </ul>
Conducted Immunity	<ul style="list-style-type: none"> <li>• EN61000-4-6, level 3 Perf Criteria A</li> </ul>
Dips and Interruptions	<ul style="list-style-type: none"> <li>• EN61000-4-11, 30% 10 ms, 60% 100 ms, 100% 5000 ms, Perf Criteria A, B, EN60601-1, 30% 500 ms, 60% 100 ms, 100% 10 ms, 100% 5000 ms, Perf Criteria A, A (with 60% load), A, B</li> </ul>
Safety Approvals	<ul style="list-style-type: none"> <li>• EN60601-1, ANSI/AAMI ES60601-1, CSA22.2 No.60601-1 per cUL, Including Risk Management XM Models, EN60950, UL60950 X Models</li> </ul>

### Notes

1. Current specifications double for DD chassis versions.  
(Low leakage for EN60601-1-2 available as modified standard, contact sales)

# Configuration - Model Number Construction

The flexPower range allows for simple configuration of a custom modular power supply with up to twenty outputs. The chassis consists of either ten, twelve or fourteen slots, and modules are either two or three slots wide. Please refer to next page for specific X15 configuration information.

## CHASSIS

## OUTPUT MODULES 1-5 (1-6: 900 W chassis/ 1-7: 1000 W chassis)

## OPTIONS

X X X X

MOD.1 MOD.2 MOD.3 MOD.4 MOD.5 MOD.6 MOD.7

P P S S + +

Model	Sector	Vinput				Slots
		115 V		230 V		
		Pnom	Ppk*	Pnom	Ppk*	
X4	Industrial	400 W	800 W	600 W	1200 W	10
XM4	Medical	400 W	800 W	600 W	1200 W	10
X5	Industrial	500 W	800 W	700 W	1200 W	10
XM5	Medical	500 W	800 W	700 W	1200 W	10
X7	Industrial	700 W	800 W	900 W	1200 W	10
XM7	Medical	700 W	800 W	900 W	1200 W	10
X9	Industrial	900 W	1100 W	1100 W	1500 W	12
XM9	Medical	900 W	1100 W	1100 W	1500 W	12
X10	Industrial	1000 W	1300 W	1200 W	1600 W	14
XM10	Medical	1000 W	1300 W	1200 W	1600 W	14
X15	Industrial	1500 W	1500 W	2500 W	2500 W	20
XM15	Medical	1500 W	1500 W	2500 W	2500 W	20

Note: Peak power available for 10 seconds with 35% duty cycle.

### Step 1

To configure your flexPower unit, select the required output power and application type. flexPower chassis are available in five industrial and five medical power formats, detailed above.

### Step 2

flexPower can accommodate up to seven modules, resulting in an extensive range of output combinations. However, as all modules are designed to fit across either two or three-slots in the chassis, configuration is very simple. Select the appropriate modules for your output requirements, ensuring that all modules will fit in the chassis. Insert 3 series modules first, then the lowest voltage for same module width. Follow with 2 series single output, lowest voltage to highest voltage, then 5 series multi-output, ordered alphabetically a-z. Then 1 series, single output modules, lowest voltage to highest voltage.

### Step 3

Add any required options. These are grouped into three types; parallel options, series options and other options. The standard signal set for each chassis includes Global Inhibit, Global DC OK and Global AC OK, each having logic 0 operation. Optionally a logic 1 operating version of each is available along with reverse air flow. Also available is a fan speed control card option, which is available separately or combined with previously listed options.

## Example

- X7 - 700 W industrial chassis, 10 module slots available.
- 3C - 3.3 V @ 60.0 A. Three slot width module.
- 3L - 15.0 V @ 20.0 A. Three slot width module.
- 2C - 3.3 V @ 40.0 A. Two slot width module.
- 00 - No parallel option.
- 23 - Modules 2 and 3 in series to give 18.3 V @ 20.0 A.
- 16 - Fan speed control card.

Single Output - Module Voltage/Current Rating						
Voltage	Current	Ipk	Power	Ppk	Slots	Code
3.3 V	20.0 A	n/a	66 W	n/a	2	1C
3.3 V	40.0 A	n/a	132 W	n/a	2	2C
3.3 V	60.0 A	n/a	198 W	n/a	3	3C
5.0 V	20.0 A	n/a	100 W	n/a	2	1D
5.0 V	40.0 A	n/a	200 W	n/a	2	2D
5.0 V	60.0 A	n/a	300 W	n/a	3	3D
12.0 V	8.50 A	n/a	102 W	n/a	2	1J
12.0 V	17.0 A	n/a	204 W	n/a	2	2J
12.0 V	25.0 A	n/a	300 W	n/a	3	3J
15.0 V	7.00 A	n/a	105 W	n/a	2	1L
15.0 V	14.0 A	n/a	210 W	n/a	2	2L
15.0 V	20.0 A	n/a	300 W	n/a	3	3L
24.0 V	5.00 A	n/a	120 W	n/a	2	1P
24.0 V	10.5 A	n/a	252 W	n/a	2	2P
24.0 V	17.0 A	n/a	408 W	n/a	3	3P
24.0 V	5.00 A	10.0 A	120 W	240 W	2	1R <sup>(1)</sup>
24.0 V	10.5 A	21.0 A	252 W	504 W	2	2R <sup>(1)</sup>
24.0 V	17.0 A	34.0 A	408 W	816 W	3	3R <sup>(1)</sup>
28.0 V	4.50 A	n/a	126 W	n/a	2	1Q
28.0 V	9.00 A	n/a	252 W	n/a	2	2Q
28.0 V	14.0 A	n/a	392 W	n/a	3	3Q
36.0 V	3.50 A	n/a	126 W	n/a	2	1U
36.0 V	7.00 A	n/a	252 W	n/a	2	2U
36.0 V	11.0 A	n/a	396 W	n/a	3	3U
48.0 V	2.50 A	n/a	120 W	n/a	2	1W
48.0 V	5.20 A	n/a	249 W	n/a	2	2W
48.0 V	8.50 A	n/a	408 W	n/a	3	3W
60.0 V	2.00 A	n/a	120 W	n/a	2	1Y
60.0 V	4.20 A	n/a	252 W	n/a	2	2Y
60.0 V	7.00 A	n/a	420 W	n/a	3	3Y

1. Peak power available for 10 seconds with 35% duty cycle, if peak power rating is exceeded output may latch, recycle input to reset.

Dual Output - Module Voltage/Current Rating					
Output 1		Output 2		Slots	Code
Voltage	Current	Voltage	Current		
5.0 V	10.0 A	5.0 V	10.0 A	2	5A
5.0 V	10.0 A	3.3 V	10.0 A	2	5B
12.0 V	10.0 A	12.0 V	8.0 A	2	5D
15.0 V	8.0 A	15.0 V	6.0 A	2	5E
15.0 V	8.0 A	12.0 V	8.0 A	2	5F
12.0 V	10.0 A	5.0 V	10.0 A	2	5G
12.0 V	10.0 A	3.3 V	10.0 A	2	5H
12.0 V	10.0 A	2.0 V	10.0 A	2	5J
15.0 V	10.0 A	5.0 V	10.0 A	2	5K
15.0 V	10.0 A	3.3 V	10.0 A	2	5L
15.0 V	10.0 A	2.0 V	10.0 A	2	5M
24.0 V	6.0 A	5.0 V	10.0 A	2	5N
24.0 V	6.0 A	3.3 V	10.0 A	2	5P
24.0 V	6.0 A	2.0 V	10.0 A	2	5Q

Note: Total power for dual output module must not exceed 175 W max.

## X7-3C3L2C-002316

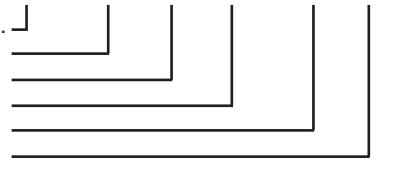

Parallel Option Codes	
Code	Description
00	No parallel required
12	Modules 1 & 2
13	Modules 1 to 3
14	Modules 1 to 4
23	Modules 2 & 3
24	Modules 2 to 4
25	Modules 2 to 5
34	Modules 3 & 4
35	Modules 3 to 5
40	Modules 1 & 2, 3 & 4

Series Option Codes	
Code	Description
00	No series required
12	Modules 1 & 2
13	Modules 1 to 3
23	Modules 2 & 3
24	Modules 2 to 4
40	Modules 1 & 2, 3 & 4

Other Option Codes	
Code	Description
01	Reverse Air
02	Global Enable - Logic 1
03	Option 01 & 02
04	Global DC OK - Logic 1
05	Option 01 & 04
06	Option 02 & 04
07	Option 01, 02 & 04
08	Global AC OK - Logic 1
09	Option 01 & 08
10	Option 02 & 08
11	Option 01, 02 & 08
12	Option 04 & 08
13	Option 01, 04 & 08
14	Option 02, 04 & 08
15	Option 01, 02, 04 & 08
16	Fan Speed Control
17	Option 01 & 16
18	Option 02 & 16
19	Option 04 & 16
20	Option 08 & 16
21	Option 01, 02 & 16
22	Option 01, 04 & 16
23	Option 01, 08 & 16
24	Option 02, 04 & 16
25	Option 02, 08 & 16
26	Option 04, 08 & 16
27	Option 01, 02, 04 & 16
28	Option 01, 02, 08 & 16
29	Option 02, 04, 08 & 16
30	Option 01, 02, 04, 08 & 16

Note: Fancard options 16-30 will occupy 2 slots.

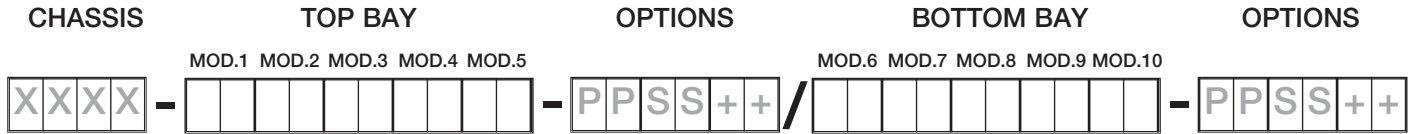

- Configuration for X15 is Chassis - Top Bay - Options / Bottom Bay - Options
- Modules for each bay are configured same as X4, X5, X7, X10.
- Maximum 1250W for each bay, power to be averaged on top and bottom bays, ±20% between top & bottom bays max deviation.
- Option codes within each bay is the same as X4 to X10.
- Fan control card mounts on bottom bay standard. For other mount location contact sales.
- 1st and 2nd digits = parallel like voltages, including vertical parallel.
- 3rd and 4th digits = series option designation.
- 5th and 6th digits = other option codes (5th and 6th digits fan card options 16 to 30 is called out for one bay only, either top or bottom).

Vertical Parallel Option Codes	
Code	Description
61	Parallel module 1 to module 1 top and bottom
62	Parallel module 2 to module 2 top and bottom
63	Parallel module 3 to module 3 top and bottom
64	Parallel module 4 to module 4 top and bottom
65	Parallel module 5 to module 5 top and bottom
91	Parallel module 1 to module 1 top and bottom, plus parallel code 12 top bay
92	Parallel module 1 to module 1 top and bottom, plus parallel code 13 top bay
93	Parallel module 1 to module 1 top and bottom, plus parallel code 14 top bay
94	Parallel module 2 to module 2 top and bottom, plus parallel code 23 top bay
95	Parallel module 2 to module 2 top and bottom, plus parallel code 24 top bay
96	Parallel module 2 to module 2 top and bottom, plus parallel code 25 top bay
97	Parallel module 3 to module 3 top and bottom, plus parallel code 34 top bay
98	Parallel module 3 to module 3 top and bottom, plus parallel code 35 top bay

Example 1

X15-3D2D2D5J-91/3D2D2C-120016

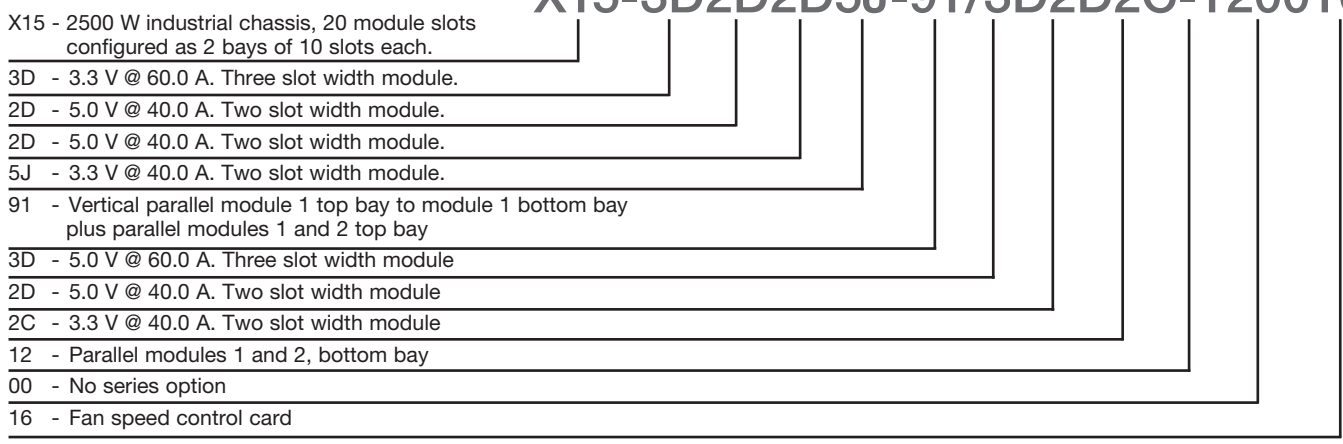

Example 2

X15-3D2D5J-61/3D2D2C-120016

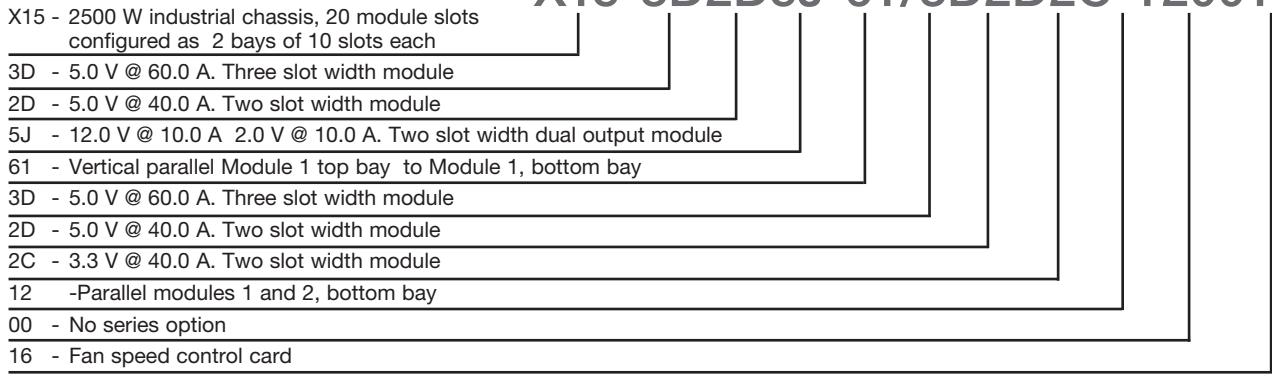

**Global AC OK/Power Fail**

Global AC OK is an isolated transistor of an optocoupler providing a minimum of 5 ms warning of loss of output regulation. The signal is fully isolated and the collector and emitter must be connected externally.

Maximum sink current 2 mA, maximum voltage 20 V.

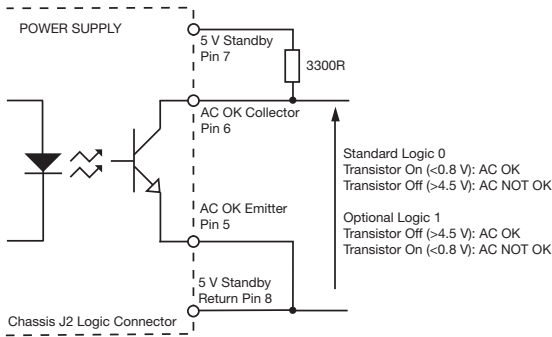

**Global DC OK**

Global DC OK is an isolated transistor of an optocoupler providing warning that the output voltage has fallen below 90% of nominal. The signal is fully isolated and the collector and emitter must be connected externally.

Maximum sink current 2 mA, maximum voltage 20 V.  
On Dual output module, DC OK monitors V1 output only.

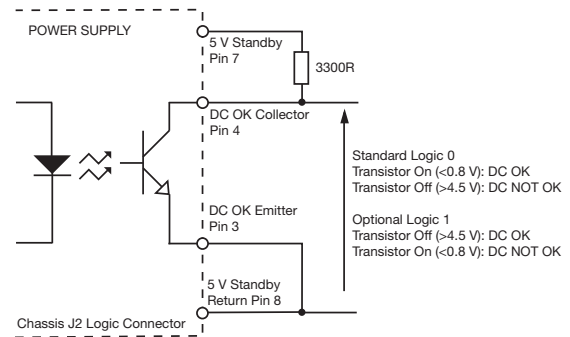

**Global Inhibit**

Global Inhibit is an isolated control signal input which turns the power supply off by supplying 2 to 5 mA into the pin. Global Enable option available, see 'Other Option Codes' table.

**Fan Fail**

When fan speed control fitted (option 16).  
Open collector signal warns of any fan failure.

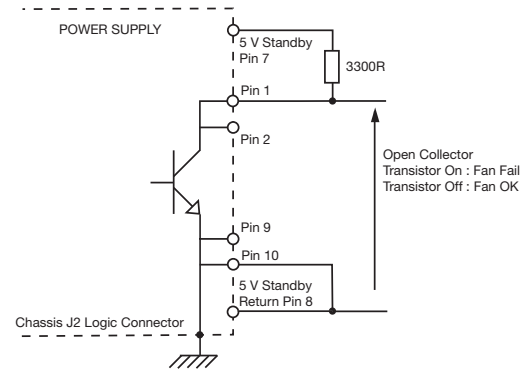
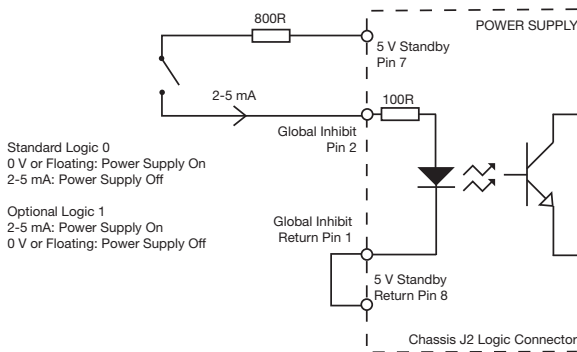

**Module DC OK**

Module DC OK is a nominal "ON" isolated transistor of an optocoupler which provides a warning of the loss of output regulation on the main output of the module.

Maximum sink current 2 mA, maximum voltage 20 V.

**Module Inhibit**

Module Inhibit signal is an isolated control signal which turns the module off by supplying 2 to 5 mA into the pin.

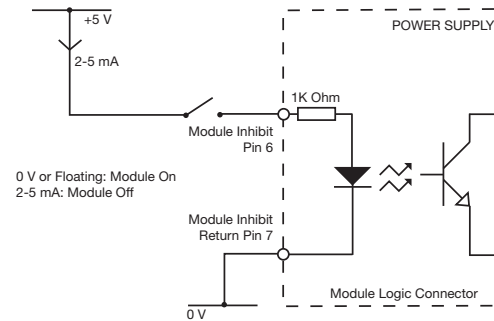
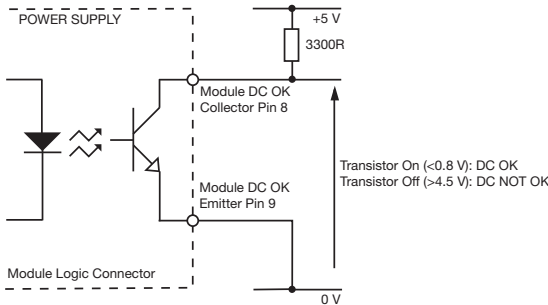

**Current Share**

Connecting pins 2 and 4 of like voltage modules (4 maximum) within the same chassis or separate chassis will force the current to share between the outputs. Different slot width modules share in proportion to their output current rating.

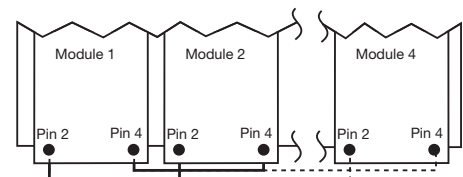

Single Output

2 Slot Modules

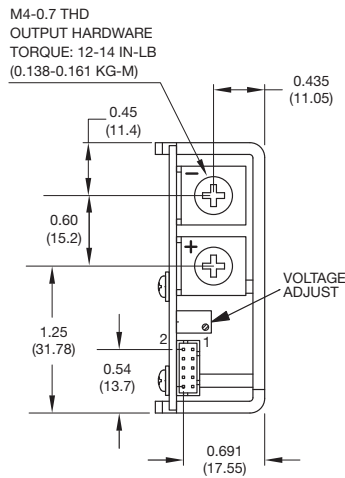

2 Slot Modules (1R / 2R Peak)

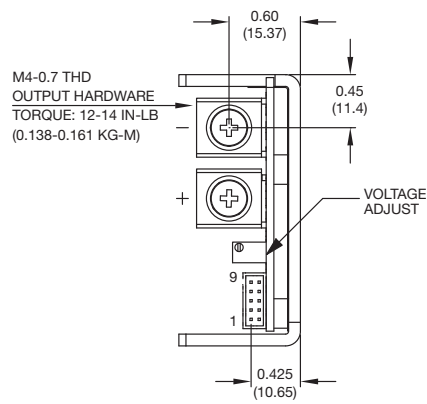

3 Slot Modules (3R Peak)

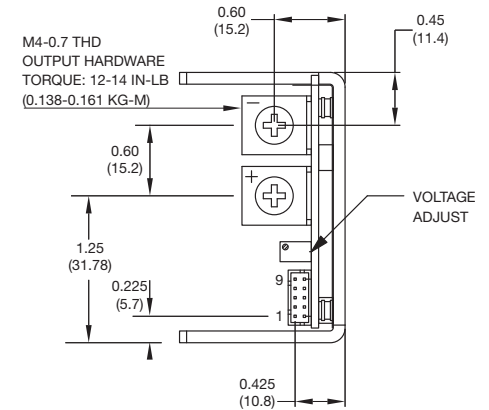

Notes

- All dimensions in inches (mm). Tolerance: .xx = ±0.02 (±0.50); .xxx = ±0.01 (±0.25)
- Weight: 2/2R Slot : 0.48 lb (218 g) approx, 3 Slot : 0.74 lb (335 g) approx.
- Mating plug: JST part no. PHDR-10VS.
- Contact: 26-22 AWG JST part no. SPHD-001T-P0.5.
- Connector kit available order part no. flexPower CONKIT.

Single Output: Module Logic Connector Pinouts			
Pin	Function	Pin	Function
1	Sense +	6	Inhibit
2	Sense -	7	Module Inhibit Return
3	V Prog	8	DC OK Collector
4	I Share	9	DC OK Emitter
5	Not used	10	Not used

Dual Output

2 Slot Modules

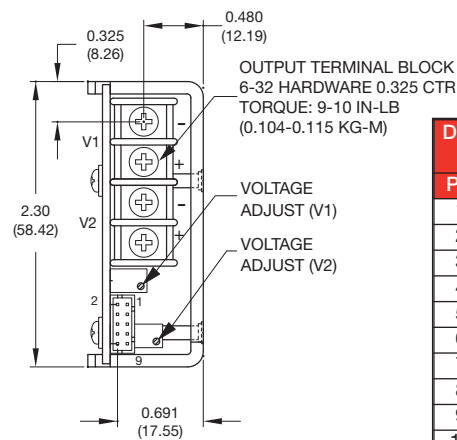

Dual Output: Module Logic Connector Pinouts	
Pin	Function
1	V1 Sense +
2	V1 Sense -
3	Not used
4	Not used
5	V2 Sense +
6	Inhibit
7	Module Inhibit Return
8	DC OK Collector
9	DC OK Emitter
10	V2 Sense -

Fan Speed Control Module

2 Slot Module

Controls speed of fan(s) depending on output load and thermal environment of the power supply. Also provides warning of any fan failure.

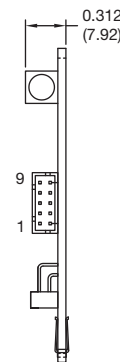

Fan Speed Control Module Connector Pinouts	
Pin	Function
1	Fan Fail
2	Fan Fail
3	Not Used
4	Not Used
5	Not Used
6	Not Used
7	Not Used
8	Not Used
9	Ground
10	Ground

Notes

- All dimensions in inches (mm). Tolerance: .xx = ±0.02 (±0.50); .xxx = ±0.01 (±0.25).
- Weight: 0.48 lb (218 g) approx.
- Mating plug: JST part no. PHDR-10VS.
- Contact: 26-22 AWG JST part no. SPHD-001T-P0.5.
- Connector kit available order part no. flexPower CONKIT.

Notes

- All dimensions in inches (mm). Tolerance: .xx = ±0.02 (±0.50); .xxx = ±0.01 (±0.25).
- Weight: 0.10 lb (45 g) approx.
- Mating plug: JST part no. PHDR-10VS.
- Contact: 26-22 AWG JST part no. SPHD-001T-P0.5.
- Connector kit available order part no. flexPower CONKIT.

## 400 (600)<sup>(4)</sup> Watt X4 & XM4 Chassis, 500 (700)<sup>(4)</sup> Watt X5 & XM5 Chassis, 700 (900)<sup>(4)</sup> Watt X7 & XM7 Chassis

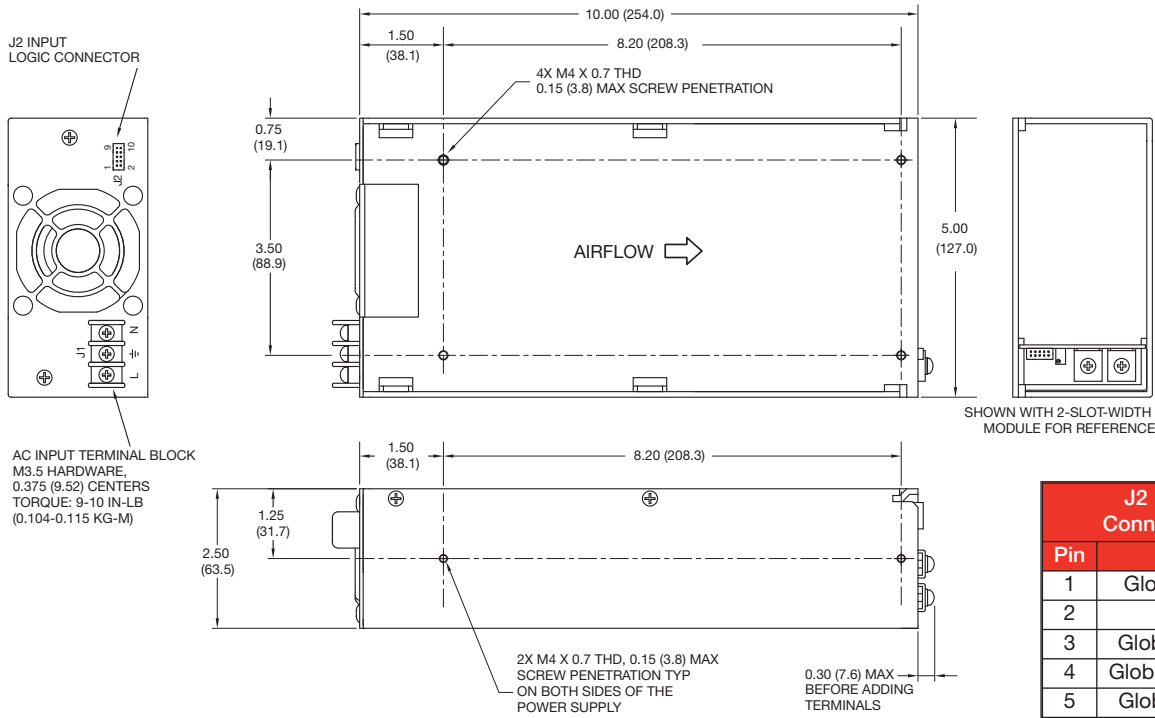

J2 Input Logic Connector Pinouts	
Pin	Function
1	Global Inhibit Return
2	Global Inhibit
3	Global DC OK Emitter
4	Global DC OK Collector
5	Global AC OK Emitter
6	Global AC OK Collector
7	5V Standby
8	5V Standby Return
9	Manufacturer Use Only
10	Manufacturer Use Only

## 900 (1100)<sup>(4)</sup> Watt X9 & XM9 Chassis

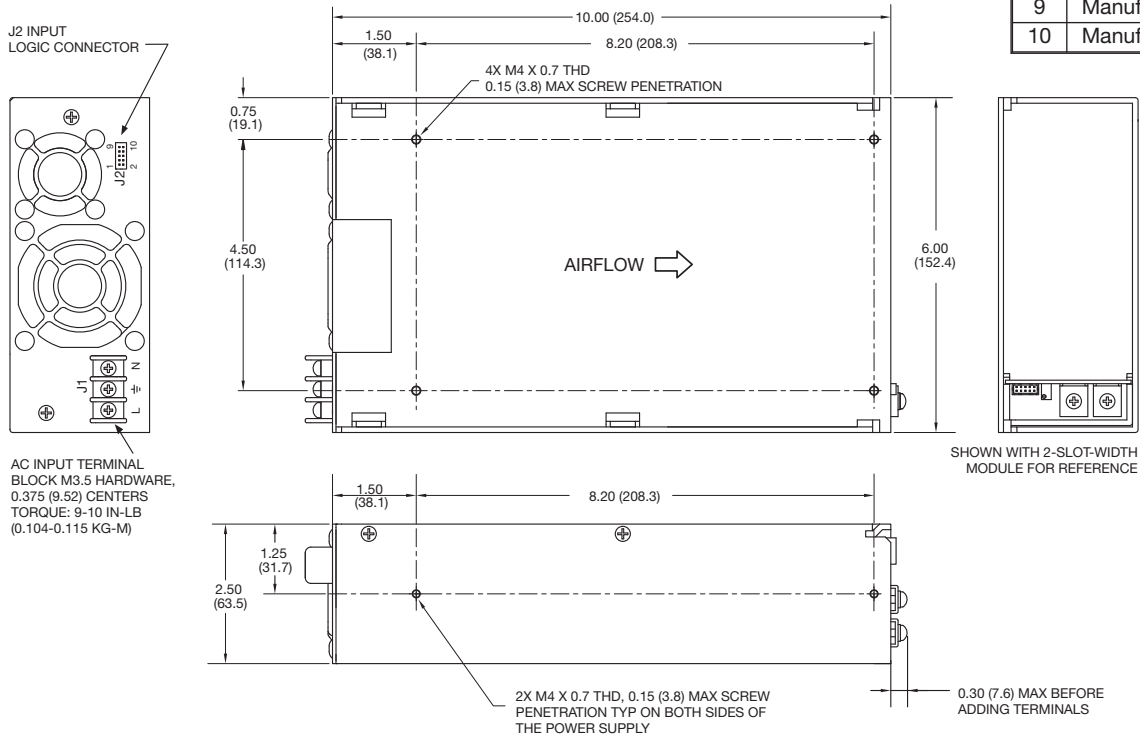

### Notes

- All dimensions in inches (mm).  
Tolerance X.XX = ±0.02 (0.05), X.XXX = ±0.01 (0.25)
- Mating plug: JST p/n PHDR-10VS.
- Contact: 26-22 AWG JST p/n SPHD-001T-P0.5.
- High line only (180-264 VAC).
- Weights: 400 (600) W X4 & XM4 chassis: 2.75 lbs (1250 g) approx.  
500 (700) W X5 & XM5 chassis: 2.75 lbs (1250 g) approx.  
700 (900) W X7 & XM7 chassis: 2.75 lbs (1250 g) approx.  
900 (110) W X9 & XM9 chassis: 3.3 lbs (1500 g) approx.

# Chassis Mechanical Details

## 1000 (1200) <sup>(4)</sup> Watt X10 & XM10 Chassis

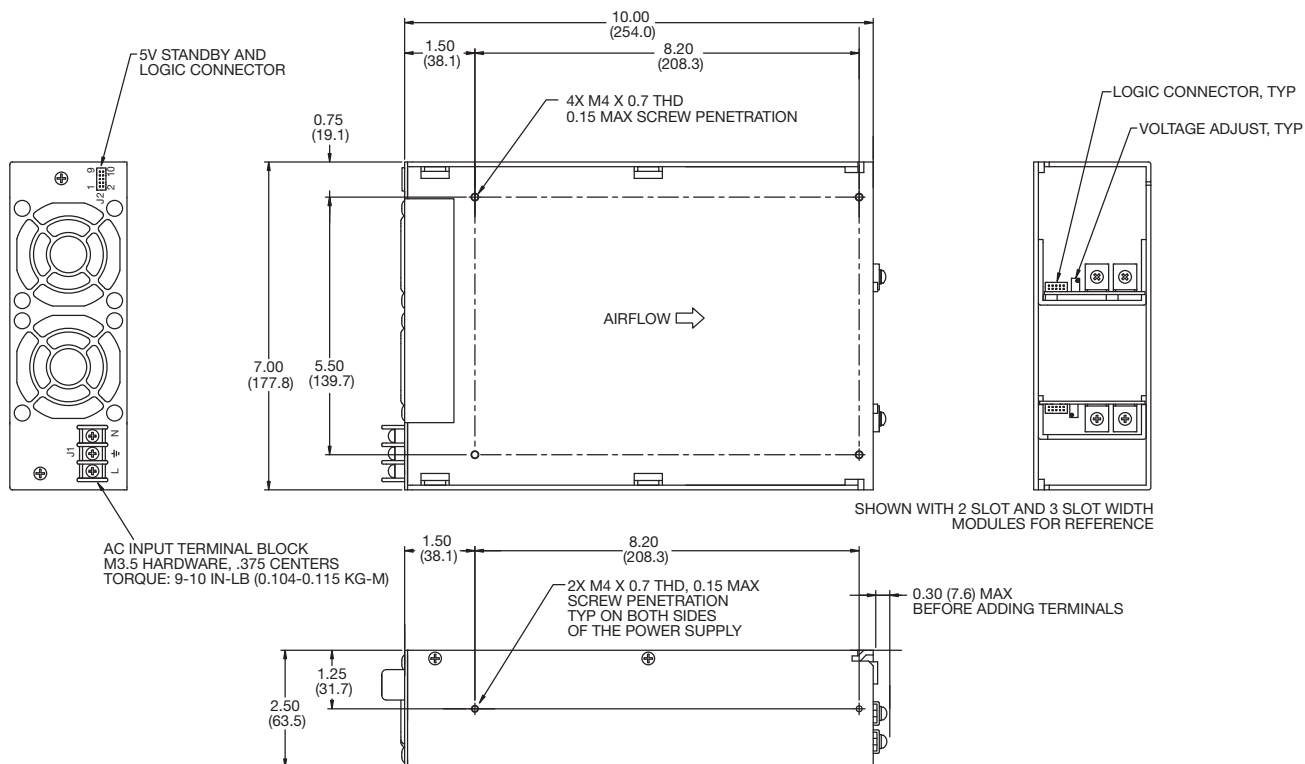

J2 Input Logic Connector Pinouts	
Pin	Function
1	Global Inhibit Return
2	Global Inhibit
3	Global DC OK Emitter
4	Global DC OK Collector
5	Global AC OK Emitter
6	Global AC OK Collector
7	5V Standby
8	5V Standby Return
9	Manufacturer Use Only
10	Manufacturer Use Only

### Notes

1. All dimensions in inches (mm). Tolerance X.XX = ±0.02 (0.05), X.XXX = ±0.01 (0.25)
2. Mating plug: JST p/n PHDR-10VS.
3. Contact: 26-22 AWG JST p/n SPHD-001T-P0.5.
4. High line only (180-264 VAC).
5. Weight: 4 lbs (1800 g) approx.

# Chassis Mechanical Details

**800 (1200)<sup>(4)</sup> Watt X4DD & XM4DD Chassis, 1000 (1400)<sup>(4)</sup> Watt X5DD & XM5DD Chassis  
1400 (1800)<sup>(4)</sup> Watt X7DD & XM7DD Chassis**

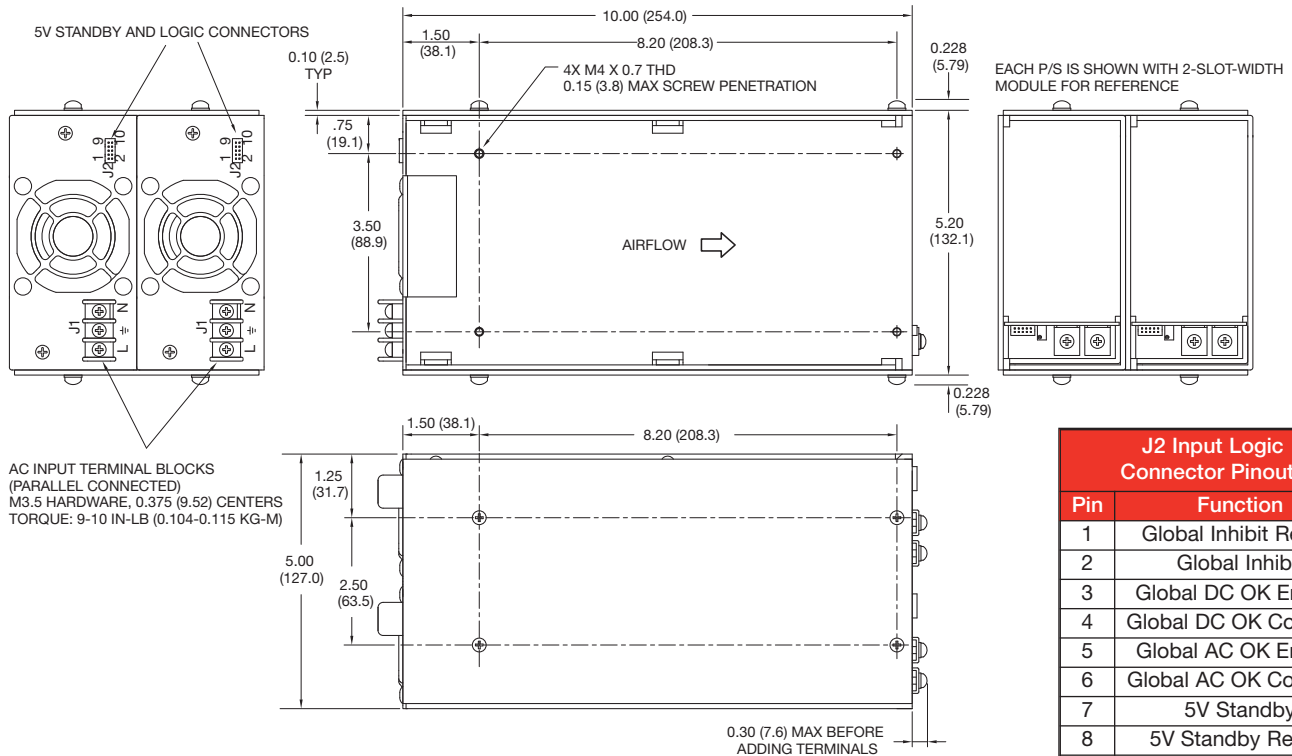

J2 Input Logic Connector Pinouts	
Pin	Function
1	Global Inhibit Return
2	Global Inhibit
3	Global DC OK Emitter
4	Global DC OK Collector
5	Global AC OK Emitter
6	Global AC OK Collector
7	5V Standby
8	5V Standby Return
9	Inhibit Sum
10	VCC Return

**1800 (2200)<sup>(4)</sup> Watt X9DD & XM9DD Chassis**

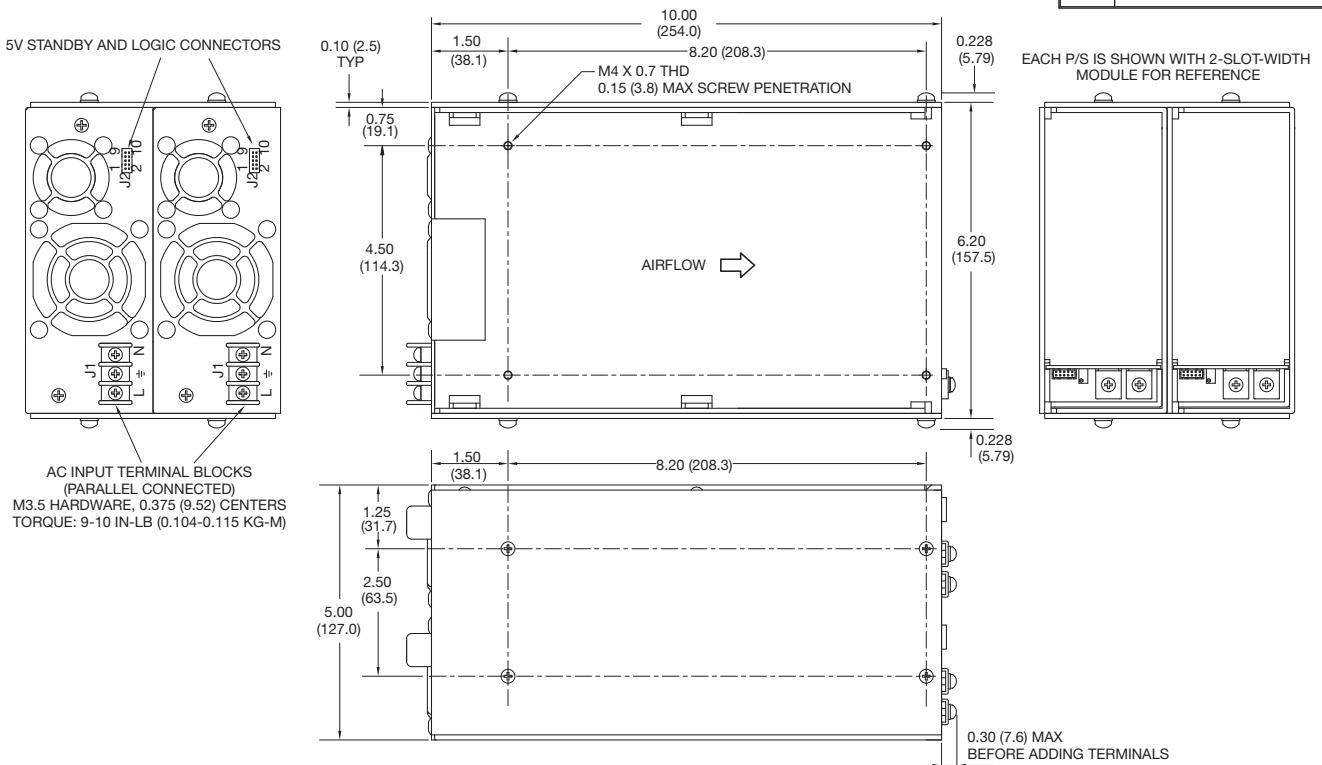

## Notes

- All dimensions in inches (mm).  
Tolerance X.XX = ±0.02 (0.05), X.XXX = ±0.01 (0.25)
- Mating plug: JST p/n PHDR-10VS.
- Contact: 26-22 AWG JST p/n SPHD-001T-P0.5.
- High line only (180-264 VAC).
- Weights: 800 (1200) W X4DD & XM4DD chassis: 5.5 lbs (2500 g) approx.  
1000 (1400) W X5DD & XM5DD chassis: 5.5 lbs (2500 g) approx.  
1400 (1800) W X7DD & XM7DD chassis: 5.5 lbs (2500 g) approx.  
1800 (2200) W X9DD & XM9DD chassis: 6.6 lbs (3000 g) approx.

2000 (2400)<sup>(4)</sup> Watt X10DD & XM10DD Chassis

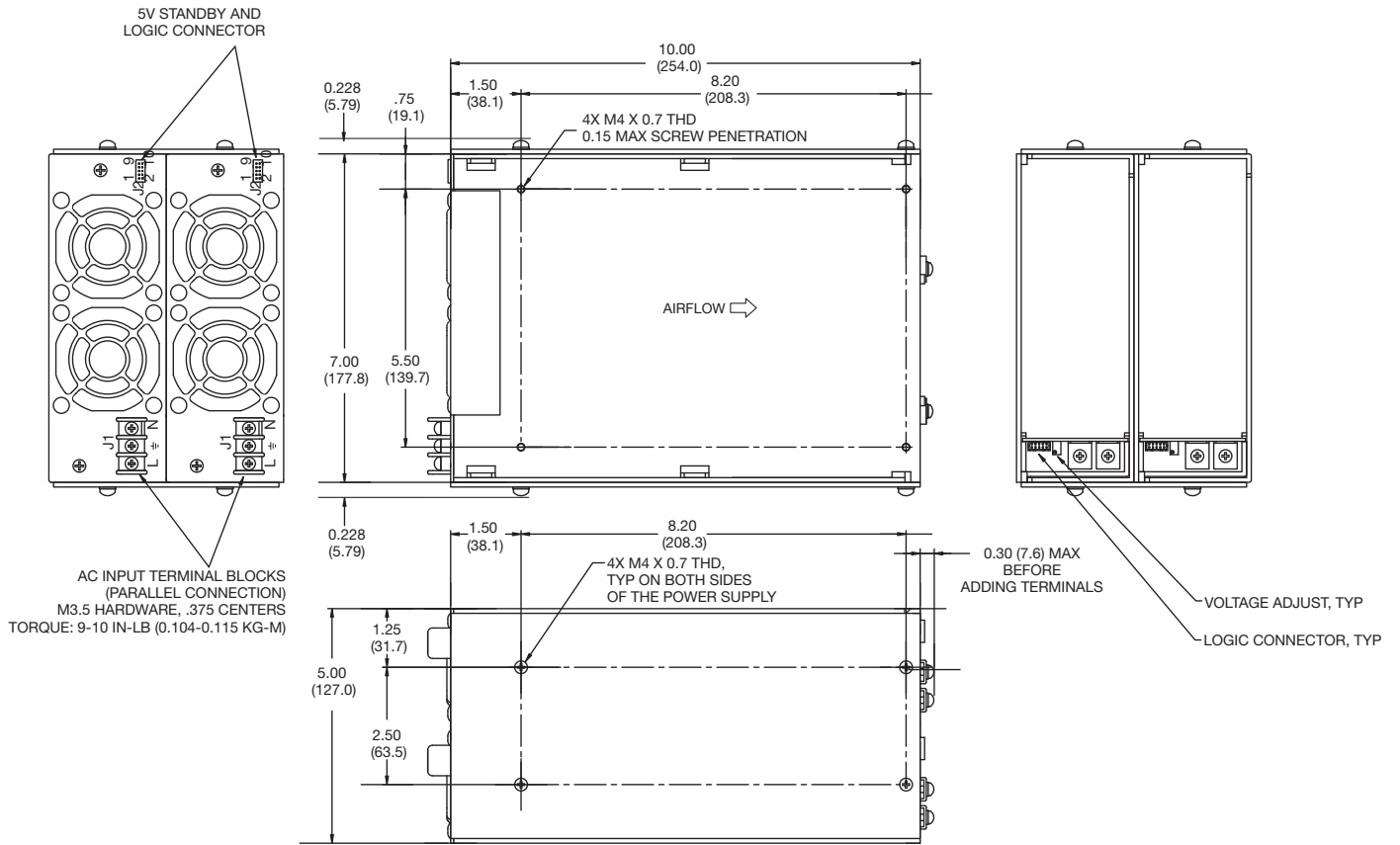

J2 Input Logic Connector Pinouts	
Pin	Function
1	Global Inhibit Return
2	Global Inhibit
3	Global DC OK Emitter
4	Global DC OK Collector
5	Global AC OK Emitter
6	Global AC OK Collector
7	5V Standby
8	5V Standby Return
9	Inhibit Sum
10	VCC Return

Notes

- All dimensions in inches (mm).  
Tolerance X.XX = ±0.02 (0.05), X.XXX = ±0.01 (0.25)
- Mating plug: JST p/n PHDR-10VS.
- Contact: 26-22 AWG JST p/n SPHD-001T-P0.5.
- High line only (180-264 VAC).
- Weight: 8.0 lbs (3636 g) approx.

1500 (2500)<sup>(4)</sup> Watt X15 & XM15 Chassis

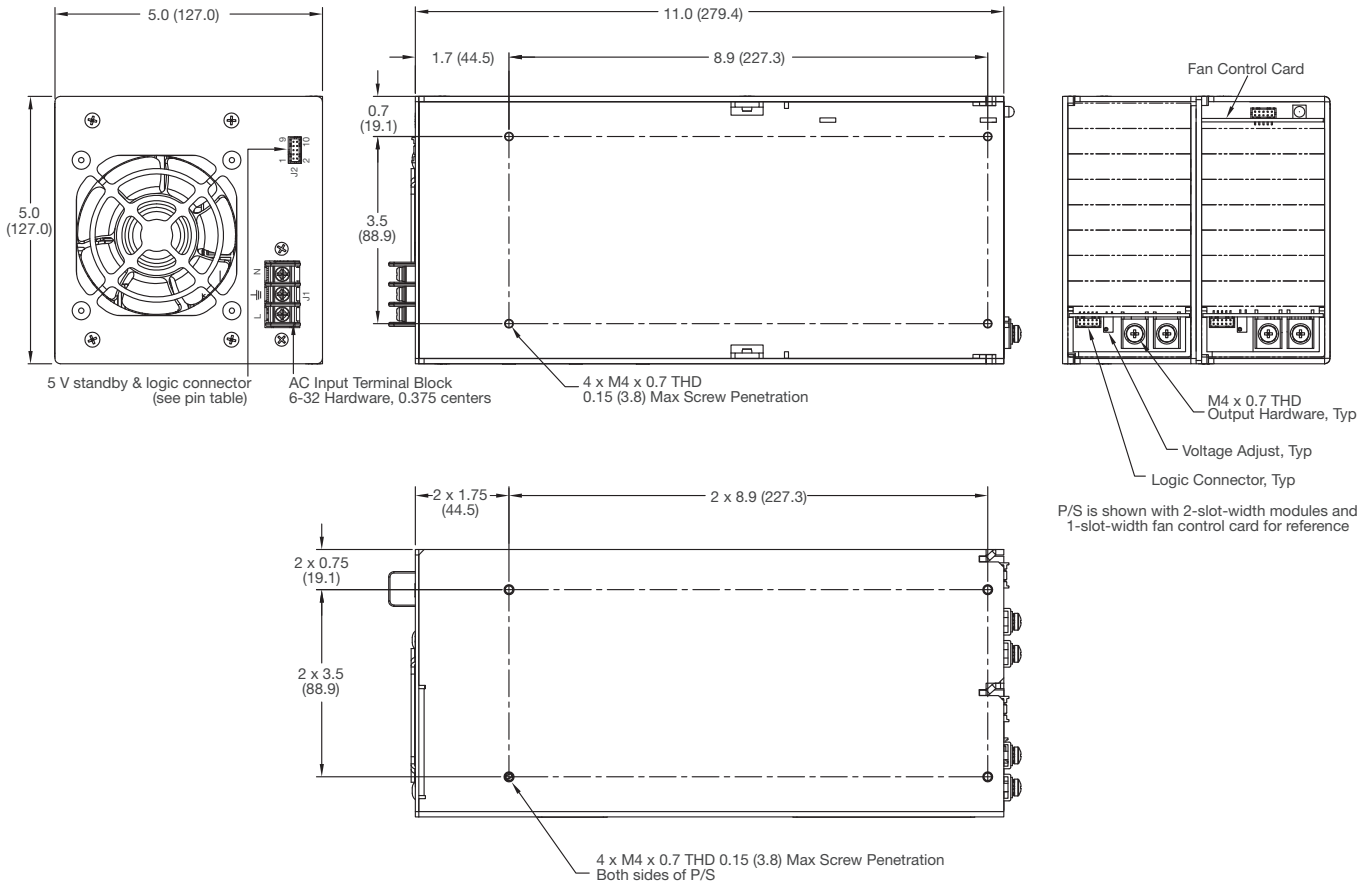

P/S is shown with 2-slot-width modules and 1-slot-width fan control card for reference

J2 Input Logic Connector Pinouts	
Pin	Function
1	Global Inhibit Return
2	Global Inhibit
3	Global DC OK Emitter
4	Global DC OK Collector
5	Global AC OK Emitter
6	Global AC OK Collector
7	5V Standby
8	5V Standby Return
9	Inhibit Sum (Internal Use Only)
10	VCC Return (Internal Use Only)

Notes

- All dimensions in inches (mm).  
Tolerance X.XX = ±0.02 (0.05), X.XXX = ±0.01 (0.25)
- Mating plug: JST p/n PHDR-10VS.
- Contact: 26-22 AWG JST p/n SPHD-001T-P0.5.
- High line only (180-264 VAC).
- Weight: 8.0 lbs (3636 g) approx.