

## ECS Series

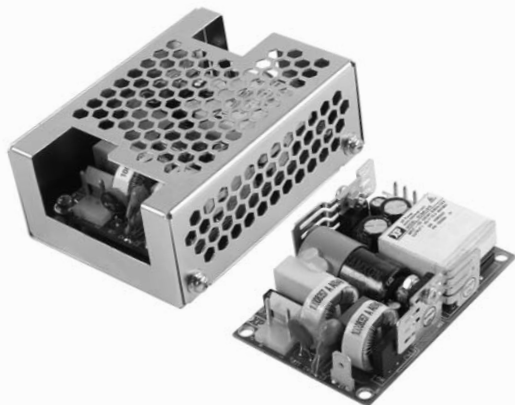

- IT & Medical Safety Approvals
- Very Small 3" x 2" x 0.95" Package
- <0.3 W Standby Power
- 25 & 45 W - Convection Cooled Ratings
- Class I & Class II Installations
- -20 °C to +70 °C Operation
- 3 Year Warranty

## Specification

## Input

Input Voltage	• 80-264 VAC (120-370 VDC), see derating curve
Input Frequency	• 47-400 Hz (See note 1)
Input Current	• 0.75 A typical at 115 VAC, full load • 0.45 A typical at 230 VAC, full load
Inrush Current	• 40 A max at 230 VAC, cold start 25 °C
Power Factor	• EN61000-3-2, class A
No Load Input Power	• US05, 12 & 24 models <0.3 W, US48 <0.5 W
Earth Leakage Current	• 260 µA at 264 VAC/60 Hz max, 80/160 µA typical 115/230 VAC
Input Protection	• T3.15 A/250 V internal fuse in line and neutral

## Output

Output Voltage	• 05-48 VDC (see tables)
Output Voltage Trim	• ±10%
Initial Set Accuracy	• ±1%
Minimum Load	• No minimum load required
Start Up Delay	• 1 s typical
Start Up Rise Time	• 50 ms
Hold Up Time	• 16 ms min at 115 VAC
Drift	• ±0.2% after 20 min warm up
Line Regulation	• ±0.5% max
Load Regulation	• ±1%
Over/Undershoot	• 5% typical
Transient Response	• 4% max. deviation, recovery to within 1% in 500 µs for a 50-75-50% load change
Ripple & Noise	• 1% pk-pk V1, 20 MHz bandwidth
Overvoltage Protection	• 115-140% Vnom, recycle input to reset
Overload Protection	• 110-200%
Short Circuit Protection	• Continuous trip and restart (Hiccup mode)
Temperature Coefficient	• 0.05%/°C

## General

Efficiency	• 87% typical
Isolation	• 4000 VAC Input to Output, 1500 VAC Input to Ground, 500 VDC Output to Ground
Switching Frequency	• 65 KHz typical
Power Density	• 7.9 W/in <sup>3</sup>
MTBF	• 1072 kHrs to MIL-HDBK-217F at 25 °C, GB

## Environmental

Operating Temperature	• -20 °C to +70 °C derate linearly from +50 °C at 2.5%/°C to 50% load at +70 °C.
Cooling	• Convection
Operating Humidity	• 95% RH, non-condensing
Storage Temperature	• -40 °C to +85 °C
Operating Altitude	• 3000 m
Shock	• 30 g pk, half sine, 6 axes
Vibration	• 2 g rms, 5 Hz to 500 kHz, 3 axes

## EMC &amp; Safety

Low Voltage PSU EMC Emissions	• EN61204-3, high severity level as below • EN55022 level B conducted • EN55022 level A radiated ECS45, Level B ECS25
Harmonic Currents	• EN61000-3-2, class A
Voltage Flicker	• EN61000-3-3
Radiated Immunity	• EN61000-4-3, level 3 Perf Criteria A
EFT/Burst	• EN61000-4-4, level 3 Perf Criteria A
Surge	• EN61000-4-5, installation class 3 Perf Criteria A
Conducted Immunity	• EN61000-4-6, level 3 Perf Criteria A
Dips & Interruptions	• EN61000-4-11, 30% 10 ms, 60% 100 ms, 100% 5000 ms, Perf Criteria A, B, B, EN60601-1-2, 30% 500 ms, 60% 100 ms, 100% 10 ms, 100% 5000 ms, Perf Criteria A, A, A, B - 230 VAC. Consult longform datasheet for 115 V operation.
Safety Approvals	• IEC60950-1 CB report, UL60950-1, TUV EN60950-1 • IEC60601-1 CB report, UL60601-1, TUV 60601-1
Equipment Protection Class	• Class I and Class II

## Notes

1. Safety approvals cover frequency 47-63 Hz.

## Models and Ratings

Output Power - Convection Cooled	Output Voltage V1	Max Output Current	Model Number <sup>(1)</sup>
25 W	12.0 VDC	2.08 A	ECS25US12
25 W	15.0 VDC	1.67 A	ECS25US15
25 W	24.0 VDC	1.04 A	ECS25US24
25 W	48.0 VDC	0.52 A	ECS25US48

### Notes

1. For covered versions, add suffix '-C' to model number. Not suitable for use in class II installations, derate output by 20% with cover.

## Mechanical Details

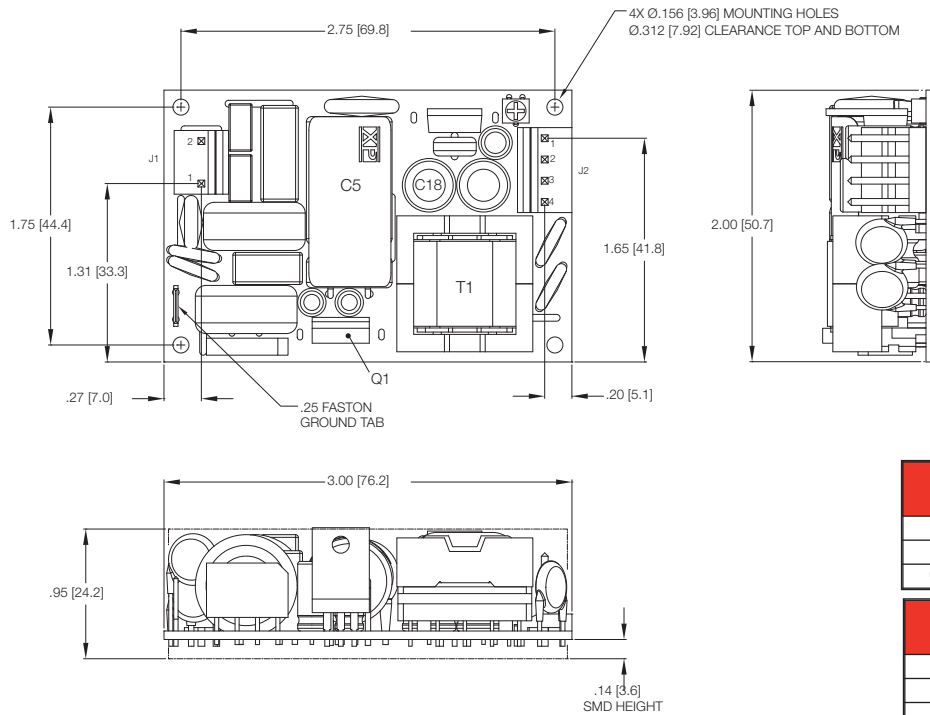

Input Connector J1 Molex PN 09-65-2038	
Pin 1	Line
Pin 2	Neutral
0.25" Faston	Earth

Input Connector J2 Molex PN 09-65-2048	
Pin 1	+V1
Pin 2	+V1
Pin 3	RTN
Pin 4	RTN

### Notes

- All dimensions in inches (mm).  
Tolerance .xx = ±0.02 (0.50); .xxx = ±0.01 (0.25)
- Weight 2.20 lbs (100 g)

J1 mates with Molex Housing PN 09-50-1031, J2 mates with Molex Housing PN 09-50-1041 and both with Molex Series 5194 Crimp Terminals

## Thermal Considerations

In order to ensure correct and reliable operation of the PSU in the most adverse conditions permitted in the end-use equipment, the temperature of the components listed in the table below must not be exceeded. See mechanical drawings for component locations. Temperature should be monitored using K type thermocouples placed on the hottest part of the component (out of any direct air flow).

Temperature Measurements (Ambient ≤ 50 ° C)	
Component	Max Temperature ° C
T1	110 °C
Q1	110 °C
C5	100 °C
C18	100 °C

Models and Ratings

Output Power - Convection Cooled	Output Voltage V1	Max Output Current	Model Number <sup>(1)</sup>
30 W	5.0 VDC	6.00 A	ECS45US05
45 W	12.0 VDC	3.75 A	ECS45US12
45 W	15.0 VDC	3.00 A	ECS45US15
45 W	24.0 VDC	1.90 A	ECS45US24
45 W	48.0 VDC	0.95 A	ECS45US48

Notes

1. For covered versions, add suffix '-C' to model number. Not suitable for use in class II installations, derate output by 20% with cover.

Mechanical Details

Weight: 2.20 lbs (100 g)  
 Dimensions shown in inches (mm).

5 V version

Input Connector J1 Molex PN 09-65-2038	
Pin 1	Line
Pin 2	Neutral
0.25" Faston	Earth

Input Connector J2 Molex PN 09-65-2048	
Pin 1	+V1
Pin 2	+V1
Pin 3	RTN
Pin 4	RTN

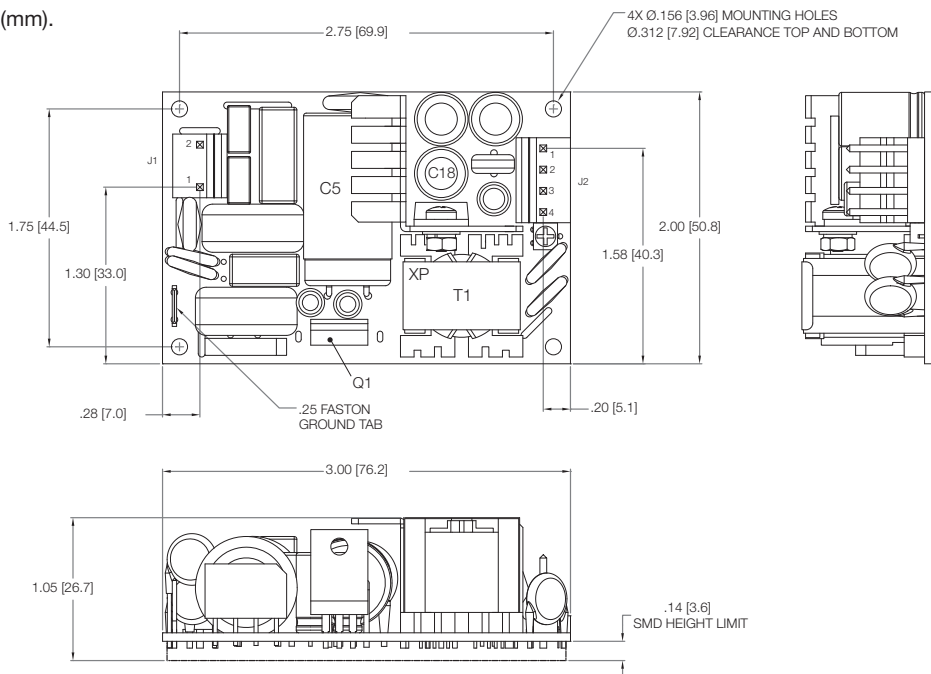

J1 mates with Molex Housing PN 09-50-1031, J2 mates with Molex Housing PN 09-50-1041 and both with Molex Series 5194 Crimp Terminals

12-48 V version

Input Connector J1 Molex PN 09-65-2038	
Pin 1	Line
Pin 2	Neutral
0.25" Faston	Earth

Input Connector J2 Molex PN 09-65-2048	
Pin 1	+V1
Pin 2	+V1
Pin 3	RTN
Pin 4	RTN

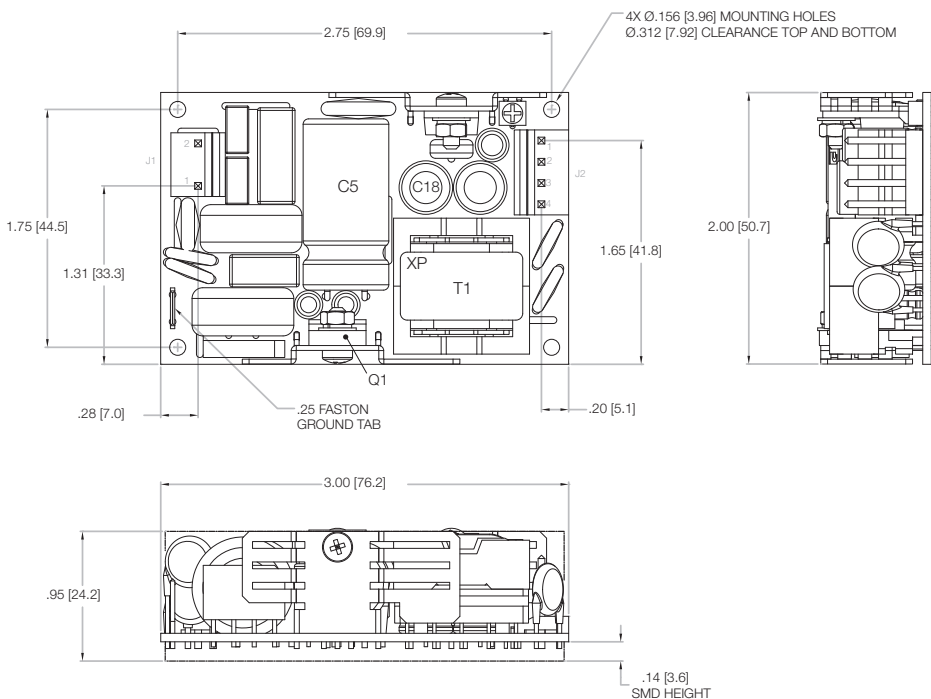

J1 mates with Molex Housing PN 09-50-1031, J2 mates with Molex Housing PN 09-50-1041 and both with Molex Series 5194 Crimp Terminals

Covered version

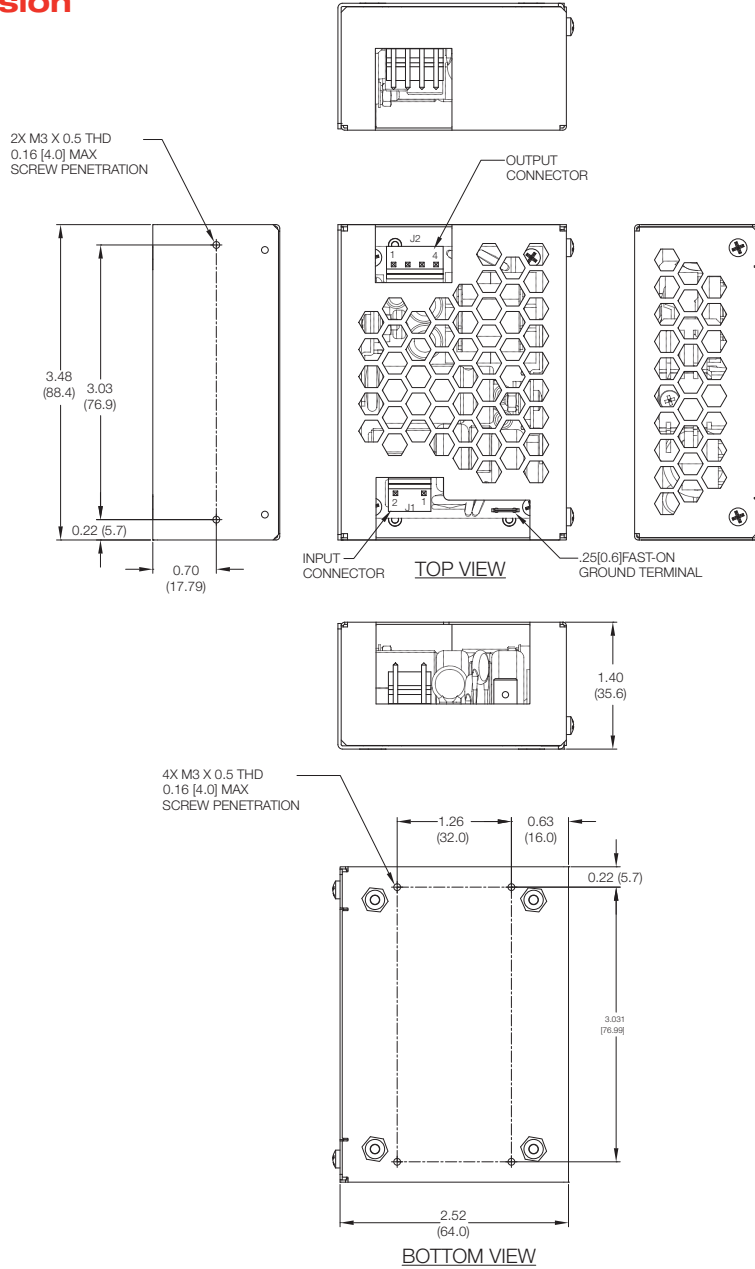

Derating Curve

