

175 Watts

CLC Series



- High Efficiency Resonant Topology
- Medical Safety Approvals (-M Versions)
- 12 V Fan Output
- Remote Sense
- 5V Standby Option
- Remote On/Off & Power Good Signal Options
- 3 Year Warranty

Specification

Input

Input Voltage	• 85-264 VAC (120-370 VDC), derate output power 10% <90 VAC
Input Frequency	• 47-63 Hz
Input Current	• 3.0 A typical at 115 VAC, full load 1.5 A typical at 230 VAC, full load
Inrush Current	• 40 A max at 230 VAC, cold start at 25 °C
Power Factor	• EN61000-3-2, class A
Earth Leakage Current	• 475 µA 264 VAC at 60 Hz, 230 µA maximum at 264 VAC at 60 Hz (-M)
Input Protection	• Internal T5 A 250 V fuse in line Internal T5 A 250 V fuse in line and neutral (-M)

Output

Output Voltage	• 12-48 V (see tables)
Output Voltage Trim	• ±5%
Initial Set Accuracy	• ±1% V1, ±5% V2, ±3% V3
Minimum Load	• 0.1 A required on V1 to maintain regulation of V2
Start Up Delay	• 1.5 s typical, see longform datasheet for more details
Start Up Rise Time	• 5 ms typical
Hold Up Time	• 16 ms min at 115 VAC
Drift	• ±0.2% after 20 min warm up
Line Regulation	• ±0.5% max
Load Regulation	• ±1% V1, ±5% V2 & V3 max
Over/Undershoot	• 5% typical
Transient Response	• 4% max. deviation, recovery to within 1% in 500 µs for a 50-75-50% load change
Ripple & Noise	• 1% pk-pk V1, others 2%, 20 MHz bandwidth
Overvoltage Protection	• 115-140% Vnom, recycle input to reset
Overload Protection	• 110-150% V1 only
Short Circuit Protection	• Continuous trip and restart (hiccup mode)
Temperature Coefficient	• 0.05%/°C
Remote Sense	• Compensates for 0.5 V total voltage drop
Remote On/Off (Inhibit/Enable) (Option -A)	• Uncommitted isolated optocoupler diode, powered diode inhibits V1 & V2

General

Efficiency	• 87% typical
Isolation	• 3000 VAC Input to Output 4000 VAC Input to Output (-M) 2 x MOPP 1500 VAC Input to Ground 1 x MOPP 500 VAC Output to Ground
Switching Frequency	• 70 kHz typical
Signals (Option -A)	• Power OK - open collector, Remote On/Off, 5 V Standby
MTBF	• 390 kHrs per MIL-HDBK-217F at 25 °C, GB
Power Density	• 9.0 W/in ³

Environmental

Operating Temperature	• 0 °C to +70 °C derate linearly from +50 °C at 2.5%/°C to 50% load at +70 °C
Cooling	• Forced-cooled >10 CFM
Operating Humidity	• 95% RH, non-condensing
Storage Temperature	• -40 °C to +85 °C
Operating Altitude	• 3000 m
Shock	• 30 g pk, half sine, 6 axes
Vibration	• 2 g rms, 5 Hz to 500 Hz, 3 axes

EMC & Safety

Low Voltage PSU EMC Emissions	• EN61204-3, high severity level • EN55011/22 level B conducted EN55011/22 level A radiated
Harmonic Currents	• EN61000-3-2, class A
Voltage Flicker	• EN61000-3-3
Radiated Immunity	• EN61000-4-3, level 3 Perf Criteria A
EFT/Burst	• EN61000-4-4, level 3 Perf Criteria A
Surge	• EN61000-4-5, installation class 3 Perf Criteria A
Conducted Immunity	• EN61000-4-6, level 3 Perf Criteria A
Dips & Interruptions	• EN61000-4-11, 30% 10 ms, 60% 100 ms, 100% 5000 ms Perf Criteria A, B, B EN60601-1, 30% 500ms, 60% 100ms, 100% 10ms, 100% 5000ms (-M) Perf Criteria A, A (with 50% load), A, B
Safety Approvals	• EN60601-1, ANSI/AAMI ES60601-1, CSA22.2 No.60601-1 per cUL, Including Risk Management, EN60950, UL60950

Output Power ⁽¹⁾	Output Voltage V1	Output Current V1	Fan Output V2	Standby Supply V3 (optional)	Model Number ^(2,3)
175 W	12.0 VDC	13.90 A	12.0 V/0.5 A	5.0 V/0.5 A	CLC175US12†^
175 W	24.0 VDC	6.90 A	12.0 V/0.5 A	5.0 V/0.5 A	CLC175US24†^
175 W	28.0 VDC	6.25 A	12.0 V/0.5 A	5.0 V/0.5 A	CLC175US28
175 W	48.0 VDC	3.50 A	12.0 V/0.5 A	5.0 V/0.5 A	CLC175US48†^

Notes

- 10 CFM airflow.
 - For medical version add, suffix '-M' to model number.
 - For 5 V standby (V3), Power OK & Inhibit, add suffix '-A' to model number.
 - For cover with Top Fan assembly add '-TF' to model number e.g. CLC175US12-TF, CLC175US12-ATF, CLC175US12-MTF or CLC175US12-MATF.
- † Available from Farnell & element14. See pages 284-290. ^ Available from Newark. See pages 291-296.

Mechanical Details

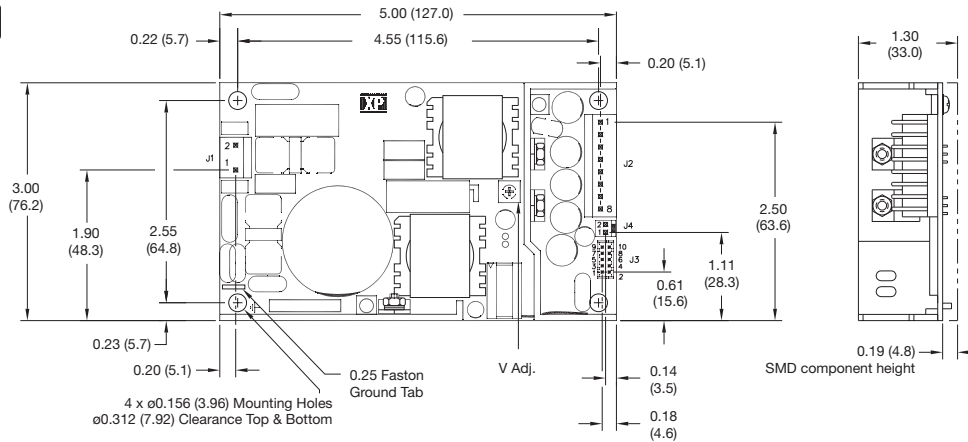

Input Connector J1	
Pin 1	Line
Pin 2	Neutral
0.25" Faston	Earth

J1 mates with Molex housing 09-50-1031 and Molex series 5194 crimp terminals.

Output Connector J2	
Pin 1	+V1
Pin 2	+V1
Pin 3	+V1
Pin 4	+V1
Pin 5	RTN
Pin 6	RTN
Pin 7	RTN
Pin 8	RTN

J2 mates with Molex housing 09-50-1081 and Molex series 5194 crimp terminals.

Signal Connector J3	
Pin 1	+5V Standby
Pin 2	Logic GND
Pin 3	Logic GND
Pin 4	Power OK
Pin 5	Inhibit HI
Pin 6	Inhibit LO
Pin 7	+Sense
Pin 8	-Sense
Pin 9	+Vout
Pin 10	-Vout

J3 mates with JST housing PHDR-10VS and JST SPHD-001T-P0.5 crimp terminals.

Fan Connector J4	
Pin 1	Fan +(12V)
Pin 2	Fan -

J4 mates with Molex housing 22-01-1024 and Molex series 5103 crimp terminals.

Fan Cover

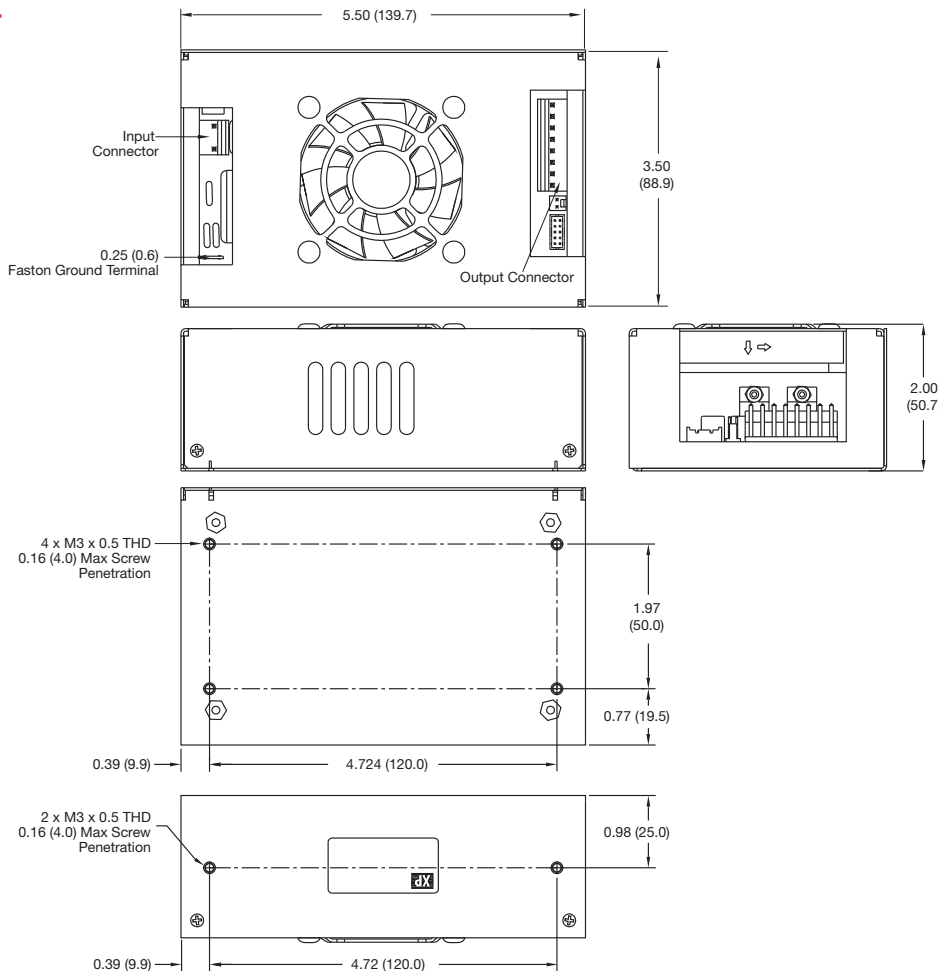

Notes

- All dimensions in inches (mm).
Tolerance .xx = ±0.02 (0.50);
.xxx = ±0.01 (0.25)
- Weight: 0.7 lbs (317 g) approx.
- For thermal derating, please refer to longform datasheet.